

# MDS-101

## SERVICE MANUAL

*US Model*  
*Canadian Model*  
*AEP Model*  
*UK Model*  
*Tourist Model*  
*Singapore Model*

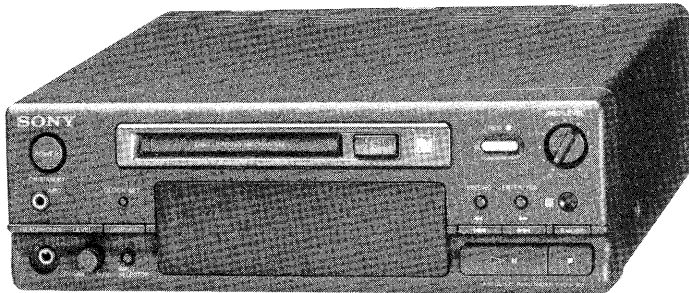

Model Name Using Similar Mechanism	NEW
Mechanism Type	MDM-1A
Base Unit Type	MBU-1A
Optical Pick-Up Block Type	KMS-140B

### SPECIFICATIONS

#### MD recorder section

System	MiniDisc digital audio system
Disc	MiniDisc
Laser:	Semiconductor laser
Wavelength:	780—790nm
Laser diode properties	Material: GaAlAs Emission duration: continuous Laser output: less than 44.6 $\mu$ W (This output is the value measured at a distance of 200 mm from the lens surface on the optical pick-up block.)
Revolutions	400 rpm to 900 rpm (CLV)
Error correction	Advanced Cross Interleave Reed Solomon Code (ACIRC)
Sampling frequency	44.1 kHz
Modulation system	EFM (Eight-to-Fourteen Modulation)
Number of channels	2 stereo channels
Frequency response	5 to 20,000 Hz $\pm$ 0.5 dB
Wow and flutter	Below measurable limit

#### Inputs

	Jack type	Input impedance	Rated input	Minimum input
MIC	Stereo mini-jack	600 ohms	0.8 mVrms	0.3 mVrms
LINE IN	Phono jack	More than 47 kilohms	500 mVrms	158 mVrms
DIGITAL IN	Square optical connector jack	Optical wave lengthh 660 nm	—	—

#### Outputs

	Jack type	Rated output	Load impedance
HEAD-PHONES	Stereo mini-jack	28 mW	32 ohms
LINE OUT	Phono jack	2 Vrms at a load impedance of 50 kilohms	More than 10 kilohms
DIGITAL OUT	Square optical connector jack	-18 dBm	Optical wave lengthh 660 nm

— Continued on next page —

**MINI DISC RECORDER**  
**SONY®**



## General

Power requirements	Model for US, Canadian : 120 V AC, 60 Hz Model for AEP : 220 - 230 V AC, 50/60 Hz Model for UK : 240 V AC, 50 Hz Model for Tourist, Singapore : 110 - 120, 220 - 240 V AC adjustable, 50/60 Hz
Power consumption	Model for US, Canadian : 22W Model for AEP, UK, Tourist, Singapore : 25W
Dimensions	Approx. 225 × 75 × 285 mm (w/h/d) (8 <sup>7</sup> / <sub>8</sub> × 3 × 11 <sup>1</sup> / <sub>4</sub> inches) incl. projecting parts
Mass	Approx. 2.9 kg (6 lb 6 oz)

## Supplied accessories

- Remote commander RM-D1M (1)
- Sony SUM-3 (NS) batteries (2)
- Audio connecting cords (pin-jack × 2 ↔ pin-jack × 2) (2)
- Audio (AU) bus cable (1)
- Recordable MD: MDW-60 (1)
- Optical cable (1) (Model for AEP, UK, Singapore)
- AC plug adapter (1) (Model for Tourist, Singapore)

## Optional accessories

- Optical cable: POC-15SP (Model for US, Canadian, Tourist)
- Recordable MDs: MDW-60 (60 min.), MDW-74 (74 min.)  
(available spring 1993)

Design and specifications are subject to change without notice.

Laser component in this product is capable of emitting radiation exceeding the limit for Class 1.

CLASS 1 LASER PRODUCT  
LUOKAN 1 LASERLAITE  
KLASS 1 LASERAPPARAT

This appliance is classified as a CLASS 1 LASER product. The CLASS 1 LASER PRODUCT MARKING is located on the rear exterior.

The following caution label is located inside of the unit.

CAUTION	: INVISIBLE LASER RADIATION WHEN OPEN. AVOID EXPOSURE TO BEAM.
ADVARSEL	: USYNLIG LASERSTRÅLING VED ÅBNING NÅR SIKKERHEDSÅFBRYDERE ER UDE AF FUNKTION. UNDGÅ UDSÆTTELSE FOR STRÅLING.
VARO!	: AVATTAESSA JA SUOJALUKITUS OHITETTAESSA DLET ALTTIINA LASERSÄTEILYLLE.
VARNING	: LASERSTRÅLING NER DENNA DEL AR OPPNAD OCH SPÅRREN ÅR URKOPPLAD.
ADVARSEL	: USYNLIG LASERSTRÅLING NÅR DEKSEL ÅPNES UNNGÅ EKSPONERING FOR STRÅLEN.



## Notes on chip component replacement

- Never reuse a disconnected chip component.
- Notice that the minus side of a tantalum capacitor may be damaged by heat.

## Flexible Circuit Board Repairing

- Keep the temperature of the soldering iron around 270 °C during repairing.
- Do not touch the soldering iron on the same conductor of the circuit board (within 3 times).
- Be careful not to apply force on the conductor when soldering or unsoldering.

## SAFETY-RELATED COMPONENT WARNING!!

COMPONENTS IDENTIFIED BY MARK  OR DOTTED LINE WITH MARK  ON THE SCHEMATIC DIAGRAMS AND IN THE PARTS LIST ARE CRITICAL TO SAFE OPERATION. REPLACE THESE COMPONENTS WITH SONY PARTS WHOSE PART NUMBERS APPEAR AS SHOWN IN THIS MANUAL OR IN SUPPLEMENTS PUBLISHED BY SONY.

## ATTENTION AU COMPOSANT AYANT RAPPORT À LA SÉCURITÉ!

LES COMPOSANTS IDENTIFIÉS PAR UNE MARQUE  SUR LES DIAGRAMMES SCHÉMATIQUES ET LA LISTE DES PIÈCES SONT CRITIQUES POUR LA SÉCURITÉ DE FONCTIONNEMENT. NE REMPLACER CES COMPOSANTS QUE PAR DES PIÈCES SONY DONT LES NUMÉROS SONT DONNÉS DANS CE MANUEL OU DANS LES SUPPLÉMENTS PUBLIÉS PAR SONY.

## TABLE OF CONTENTS

<u>Section</u>	<u>Title</u>	<u>Page</u>	<u>Section</u>	<u>Title</u>	<u>Page</u>
<b>SECTION 1. GENERAL</b>			<b>SECTION 4. DIAGRAMS</b>		
What is the MiniDisc? .....		4	4-1. Circuit Boards Location .....		38
Precautions .....		4	4-2. Block Diagram .....		39
Looking at the Controls .....		5	4-3. Printed Wiring Board — RF Section — .....		44
Hooking Up the System .....		6	4-4. Schematic Diagram — RF Section — .....		49
Setting the Clock .....		8	4-5. Printed Wiring Board — Audio Section — .....		53
Playing an MD (Normal Play) .....		9	4-6. Schematic Diagram — Audio Section — .....		57
Playing Tracks in Random Order (SHUFFLE Play) .....		11	4-7. Schematic Diagram — Digital Section — .....		61
Playing Tracks in a Specific Order (PROGRAM Play) .....		11	4-8. Printed Wiring Board — Digital Section — .....		65
Playing Tracks Repeatedly .....		12	4-9. Schematic Diagram — Display Section — .....		69
Scanning Tracks (Music Scan) .....		13	4-10. Printed Wiring Board — Display Section — .....		73
Inserting Spaces During Playback (Auto Space) .....		13	4-11. IC Block Diagrams .....		77
Recording a Digital Source .....		13	4-12. Semiconductor Lead Layouts .....		81
Recording From the Line (Analog) Input Jack .....		14	<b>SECTION 5. EXPLODED VIEWS</b>		
Recording From a Microphone .....		15	5-1. Case and Front Panel Section .....		82
Track Marking During Recording .....		16	5-2. Chassis Section .....		83
CD Synchro-Recording .....		17	5-3. Mechanism Deck Section-1 (MDM-1A) .....		84
Editing Functions for a Recorded MiniDisc .....		18	5-4. Mechanism Deck Section-2 (Slider Assy) (MDM-1A) .....		85
Erasing Recordings (ERASE Function) .....		19	5-5. Base Unit Section (MBU-1A) .....		86
Dividing Recorded Tracks (DIVIDE Function) .....		20	<b>SECTION 6. ELECTRICAL PARTS LIST .....</b>		
Combining Recorded Tracks (COMBINE Function) .....		21	87		
Moving Recorded Tracks (MOVE Function) .....		22	<b>SECTION 7. TEST MODE</b>		
Labeling Recordings (TITLE Function) .....		23	7-1. Test Mode Setting .....		99
Display Messages .....		24	7-2. Test Mode Releasing .....		99
System Limitations .....		24	7-3. Test Mode Operation .....		99
<b>SECTION 2. DISASSEMBLY</b>			<b>SECTION 8. ELECTRICAL ADJUSTMENTS</b>		
2-1. Case and Front Panel .....		25	8-1. Caution on Laser Diode Emitting Confirmation .....		101
2-2. REC VOL Board and DISP Board .....		25	8-2. Note on MiniDisc Device (KMS-140B) Handling .....		101
2-3. Digital Board .....		26	8-3. Note on Adjustment .....		101
2-4. Back Panel .....		26	8-4. Offset Adjustment .....		101
2-5. Power Transformer .....		27	8-5. Laser Power Adjustment .....		102
2-6. Mechanism Deck (MDM-1A) .....		27	8-6. MO Traverse Adjustment .....		103
2-7. RF Board .....		28	8-7. CD RF Level Adjustment .....		104
2-8. Base Unit (MBU-1A) .....		28	8-8. CD Traverse Adjustment .....		104
2-9. Loading Motor Assy .....		29	8-9. MO Focus Bias Adjustment .....		105
2-10. Sled Motor .....		29	8-10. CD Focus Bias Adjustment .....		106
2-11. Mini Disc Device (KMS-140B) .....		30	8-11. Error Rate Confirmation .....		107
<b>SECTION 3. IC PIN FUNCTIONS</b>			8-12. Adjustment Location .....		108
IC103 EFM/ACIR Encoder/Decoder (CXD2525R) .....		31			
IC110 Shockproof Memory Controller (CXD2526Q) .....		33			
IC111 Mechanism Microprocessor (M38067M8-051P) .....		35			
IC301 Master Microprocessor (M38003M8-050P) .....		37			

# SECTION 1 GENERAL

This section is extracted from instruction manual.

## What Is the MiniDisc?

### How MiniDiscs work

MiniDiscs (MD) come in two types; premastered (pre-recorded) and recordable (blank). Premastered MDs, recorded at music studios, can be played back almost endlessly. However, they can't be recorded on or over like cassette tapes. To record, you use a "recordable MD".

**Premastered MDs**  
Premastered MDs are recorded and played like regular CDs. A laser beam focuses on the pits in the surface of the MD and reflects the data back to the lens in the recorder. The recorder then decodes the signals and plays them back as music.

**Recordable MDs**  
Recordable MDs, which use magneto-optical (MO) technology, can be recorded again and again. The laser inside the recorder applies heat to the MD, demagnetizing the magnetic layer of the MD. (See illustration below.) The recorder then applies a magnetic field to the layer. This magnetic field corresponds exactly to the audio signals generated by the connected source. (The north and south polarities equate to digital "1" and "0".) The demagnetized MD adopts the polarity of the magnetic field, resulting in a recorded MD.

### Recording Mechanism

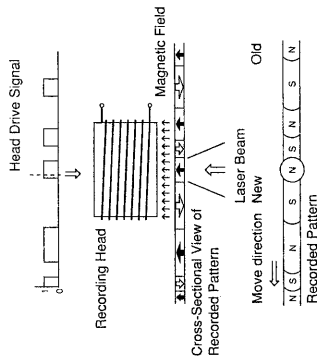

## What Is the MiniDisc?

### How the Shock-Resistant Memory works

One major drawback of optical read systems is that they can skip or mute when subjected to vibration. The MD system resolves this problem by using a buffer memory that stores up to 10 seconds of audio data. This is possible because of a 1 second lag between the time audio data is picked up and when it is decoded (see illustration below). Should the optical pickup be jarred out of position, the correct audio data plays from the buffer memory. Using a concept called "sector repositioning," the optical pickup has the ability to within 13 milliseconds identify the disruption and resume reading from the correct point. As long as the optical pickup returns to the correct position within about 10 seconds, you never experience mistracking or muting.

### Shock-Resistant Memory System

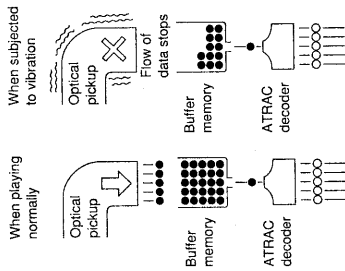

### How Quick Random Access and the TOC systems work

Like CDs, MDs offer instantaneous random access to the beginning of any music track. Premastered MDs are recorded with location addresses corresponding to each music selection. Recordable MDs are manufactured with a "User TOC" Area" to contain the order of the music. The TOC system is similar to the "directory management system" of floppy disks. In other words, starting and ending addresses for all music tracks recorded on the disc are stored in this area. This lets you randomly access the beginning of any track as soon as you enter the track number (AMS), as well as label the location with a track name as you would a file on a diskette.

\* TOC is the acronym for Table of Contents.

### Preparations

## Precautions

### On safety

- As the laser beam used in this unit is harmful to the eyes, do not attempt to disassemble the cabinet. Refer servicing to qualified personnel only.
- Should any solid object or liquid fall into the unit, unplug the unit and have it checked by qualified personnel before operating it any further.

### On power sources

- Unplug the unit from the wall outlet when it is not to be used for an extended period of time.

### On operation

- If the unit is brought directly from a cold to a warm location, or is placed in a very damp room, moisture may condense on the lenses inside the MiniDisc recorder, causing the MiniDisc recorder to operate improperly. Should this occur, remove the disc and wait about an hour for the moisture to evaporate.

### On the MiniDisc cartridge

- Do not open the shutter to expose the disc.
- Do not place the cartridge where it will be subject to extremes of sunlight, temperature, moisture or dust.

### On cleaning

- Clean the casing with a soft cloth slightly moistened with water or a mild detergent solution. Do not use any type of abrasive pad, scouring powder or solvent such as alcohol or benzene as it may mar the finish of the casing.

If you have any questions or problems concerning your unit, please consult your nearest Sony dealer.

# Looking at the Controls

## Front panel

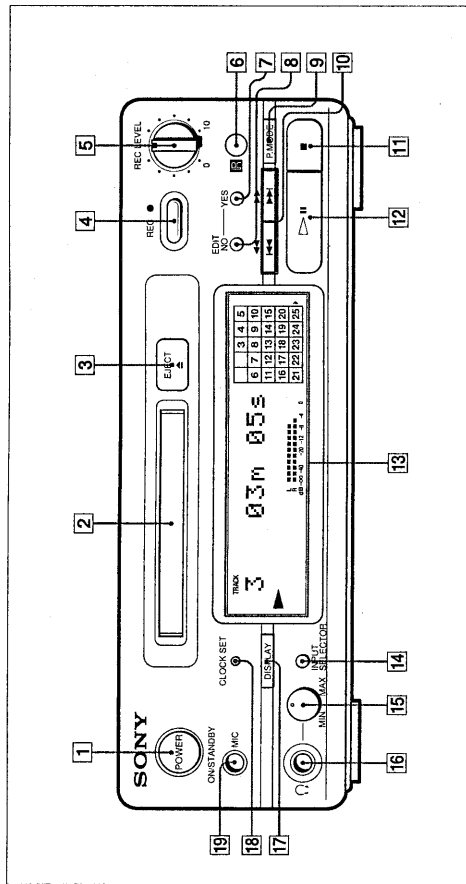

- 1 POWER switch**  
Press to turn on the unit; press again to change to stand-by.
- 2 Disc compartment**  
Automatically loads an inserted disc.
- 3 EJECT button**  
Press to eject the disc from the disc compartment.
- 4 REC (record) button**  
Press once to activate recording pause. Press **II** to start recording. Used also for track marking.
- 5 REC (recording) LEVEL control**  
Turn to adjust the recording level when recording from analog sources.
- 6 Remote sensor**  
Accepts commands from the remote commander.
- 7 YES button**  
Press to perform editing functions (i.e., erasing, dividing, combining, and moving).
- 8 EDIT button**  
Press to specify or cancel the various editing functions.
- 9 P.MODE button**  
Press to select playback modes (i.e., CONTINUE, SHUFFLE, and PROGRAM).
- 10 (AMS/search) button**  
Press to find the desired point within a track or the beginning of a track.
- 11 (Stop) button**  
Press to stop playback or recording, or to cancel program play.
- 12 (Play/Pause) button**  
Press to start playback or recording. Press during playback or recording to temporarily stop the MD; press again to cancel pause.
- 13 Display window**  
Indicates the current operating status.
- 14 INPUT SELECTOR button**  
Press to select the input signal to be recorded. Press while the unit is stopped to select "Analog in" to record in" to record through the DIGITAL IN jack.
- 15 Headphones level control**  
Turn to adjust the volume of the headphones.
- 16 Headphones jack**  
Connect headphones with a stereo mini-plug here.
- 17 DISPLAY button**  
Press to display the name of the current track and the remaining playing time on the MD.
- 18 CLOCK SET button**  
Press to set the clock.
- 19 MIC (microphone) jack**  
Connect a microphone with a stereo mini-plug here.  
\* AMS: Automatic Music Sensor

## Remote commander

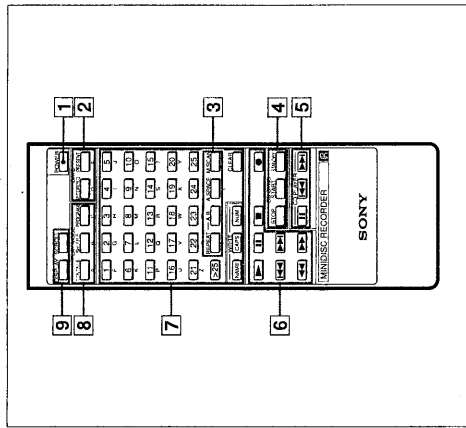

- 1 POWER switch**  
Press to turn on the unit; press again to turn off (change to stand-by).
- 2 DATE buttons**  
DATE RECORDED button  
Press to display the recording date of a track during playback.  
DATE PRESENT button  
Press to display the current time and date.
- 3 Repeat/Auto space buttons**  
REPEAT button  
Press for repeated playback.  
A-B button  
Press for repeated playback of specific portions of a track.  
A.SPACE button  
Press for automatic insertion of 3-second blank spaces between tracks during playback.  
M.SCAN button  
Press to scan the beginning of each track in succession.
- 4 CD SYNCHRO operation buttons**  
(for synchronized recording with a Sony CD player)  
STANDBY button  
Press to activate recording pause mode prior to CD synchro recording.  
START button  
Press to start CD synchro recording.  
STOP button  
Press to stop CD synchro recording.

- 5 CD player operation buttons**  
(Use to control Sony CD players)  
**II** (Pause) button  
Press to temporarily stop playback; press again to resume playback.  
**II** (AMS) buttons  
Press to find the beginning of a desired track.
- 6 Operation buttons**  
**▶** (Play) button  
Press for playback.  
**II** (Pause) button  
Press to temporarily stop playback or recording; press again to resume playback or recording.  
**■** (Stop) button  
Press to stop playback or recording. Press to cancel program play.  
**●** (Record) button  
Press once to activate recording pause. Press **▶** or **II** to start recording. Use also for track marking.  
**II** (AMS) buttons  
Press to find the beginning of a desired track.  
**◀** (Search) buttons  
Press to find a desired point within a track.
- 7 Character/Numeric buttons**  
Alphabet/Numeric buttons  
Use to specify tracks for immediate playback or to create programs during program play. Use also for entering disc and track titles.  
WRITE/CAPS, WRITE/NUM buttons  
Press to select the character mode.  
WRITE/NAME button  
Press to apply a title.  
CLEAR button  
Press to erase a track name, disc name or programmed track.
- 8 Play mode buttons**  
CONTINUE button  
Press during shuffle or program play to resume normal playback.  
SHUFFLE button  
Press to activate shuffle play.  
PROGRAM button  
Press to activate program play.
- 9 Display buttons**  
DISPLAY button  
Press to display the track name or the remaining playing time during MD playback.  
SCROLL button  
Press to scroll titles longer than 12 characters.

# Hooking Up the System

## Before you begin

- Turn off the power to all the equipment to be connected before making any connections.
- Note that the red plug of the supplied audio connecting cord is for right-channel (R) connection and the white plug for left-channel (L) connection. If another connecting cord is necessary, use the optional PK-C515HG cord.
- The connecting cords should be fully inserted into the jacks. A loose connection may cause hum pickup.
- Pull out the cords by grasping the plug, not the wire.

## Connecting the audio connecting cords

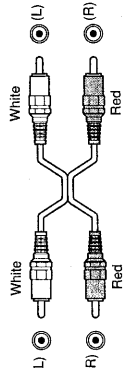

## Connecting the audio bus cable

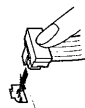

Insert the cable firmly.

The time display appears on the Mini Hi-Fi Component Systems (available at a later date) instead of the MD unit when both are connected by audio bus cable.

## Notes on the optical digital input/output jacks

Use the optional POC-15SP optical cable to connect digital devices with a sampling frequency of 44.1 kHz (i.e., DAT decks, amplifiers with digital inputs, DA converter units, etc.) to the optical digital input and output jacks. Recording level adjustment is not necessary when recording through the POC-15SP optical cable from a digital source since the output level is fixed.

## Connecting the optical cable

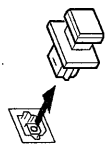

Remove the plug.

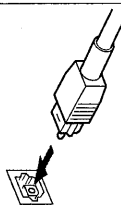

Insert the cable firmly.

## Digital sources with a different sampling frequencies

cannot be recorded through the digital input jack. Only CD, MD (premastered) and DAT sources with a sampling frequency of 44.1 kHz can be recorded through the digital input jack. "Din Unlock" appears in the display window when an attempt is made to record digital sources with a sampling frequency different from that of the MD (such as 32- or 48- kHz DAT or BS).

## Hooking up a Sony Mini Hi-Fi Component System

Hooking up a Sony Mini Hi-Fi Component System through the digital output jack (for digital recording)

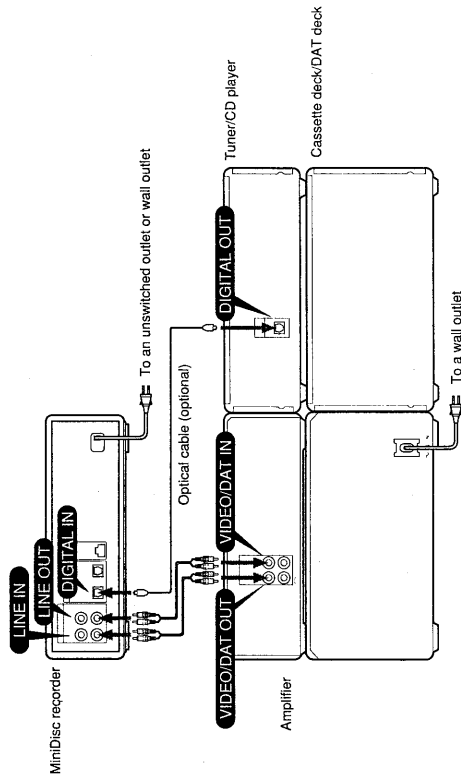

Connection to future Sony Mini Hi-Fi Component Systems with AU-bus connection capability enables the use of the automatic on/off and CD synchro recording functions.

# Hooking Up the System

## Hooking up a Sony Mini Hi-Fi Component System

Hooking up a Sony Mini Hi-Fi Component System without a digital output jack (for analog recording)

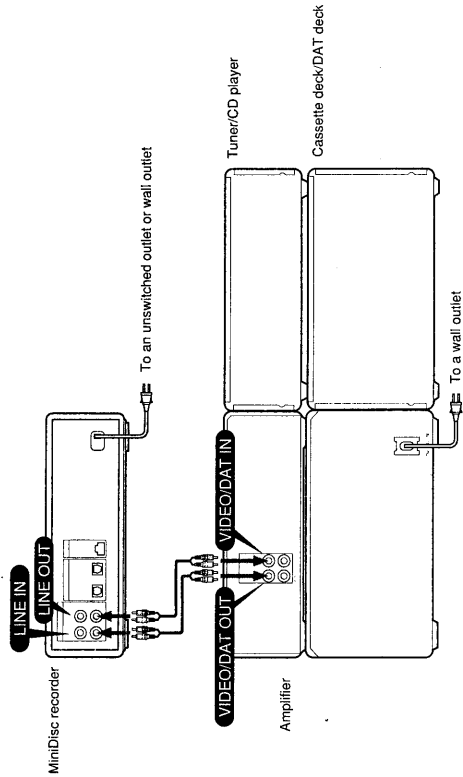

Connection to future Sony Mini Hi-Fi Component Systems with AU-bus connection capability enables the use of the automatic on/off and CD synchro recording functions.

## Hooking up other audio equipment

Hooking up other audio equipment with digital output (for digital recording)

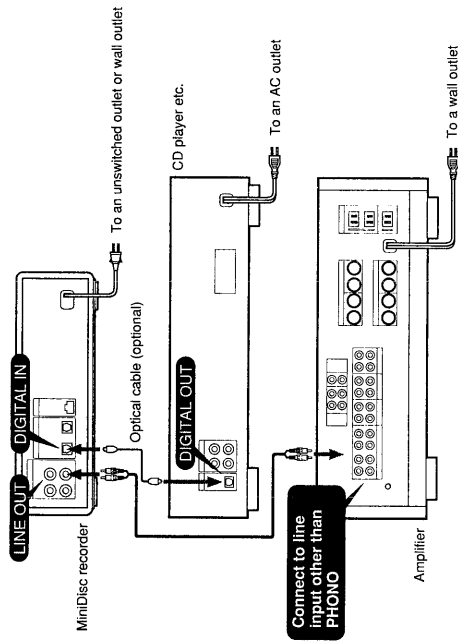

Hooking up other audio equipment without digital output (for analog recording)

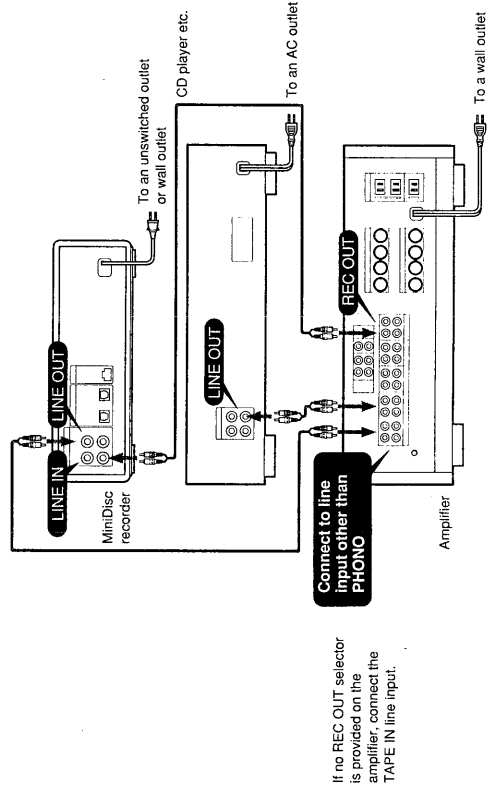

Hooking up an amplifier with digital input, DAT deck or another MiniDisc recorder  
Connect the respective equipment to the digital output of your unit.

## Hooking Up the System

### Hooking up a microphone

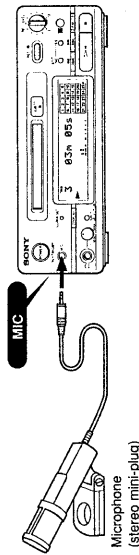

#### Note

Connecting a microphone to the MIC jack disables all other source inputs. Make sure that the microphone is disconnected from the MIC jack when not in use.

## Setting the Clock

To stamp the time and date on recordings, set the built-in clock. When playing back the recorded disc, the date and time of the recording will appear in the display window.

Example: Setting the clock to 1993, April 23, 9:10 PM.

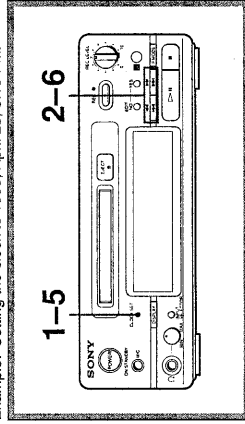

- 1 Keep pressing **CLOCK SET** for about 2 seconds until the year starts to flash.

CLOCK SET  
○

01M 01d 9:10P

- 2 Enter the current year by pressing **▲** or **▼**. Pressing **▲** increases the year and pressing **▼** decreases the year. Holding down the respective button increases or decreases the year faster. After entering the year, press **CLOCK SET**. The month flashes.

04M 01d 9:10P

- 3 Enter the month by pressing **▲** or **▼**. After entering the month, press **CLOCK SET**. The day flashes.

04M 01d 9:10P

- 4 Enter the day by pressing **▲** or **▼**. After entering the day, press **CLOCK SET**.

04M 23d 9:10P



FRI 09:10P

The day of the week automatically appears and the hour flashes.

- 5 Enter the hour by pressing **▲** or **▼**. After entering the hour, press **CLOCK SET**. The minutes flash.

FRI PM 09:10P

- 6 Enter the minutes by pressing **▲** or **▼**.

- 7 Press **CLOCK SET** in synchronization with the time signal.

04M 23d 9:10P



FRI PM 09:10

The clock setting is displayed in order of date, then time.

#### Notes

To display the current date and time Press the **CLOCK SET** button on the front panel once to display the date, then again to display the time. When using the remote commander, press the **DATE PRESENT** button. The date, then the time are displayed in sequence.

#### To change the display while the unit is off

Your unit can display either "STANDBY" or the current time when it is off (in standby mode). Choose one or the other by pressing the **DISPLAY** button.

#### For more precise time stamping of recordings

It is recommended that you set the clock once a week.



# Playing an MD (Normal Play)

## Playing an MD from the first track

Follow the procedure below to listen to an MD.

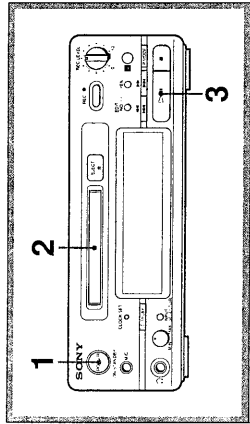

**1** Press POWER.



**2** With the label side up and the arrow pointing toward the opening, slide the MD into the disc compartment until the recorder grips it.

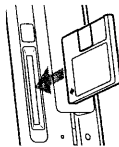

The disc name appears, followed by the total number of tracks (Tr) and total disc playing time. A music calendar showing all the track numbers appears within a grid if a premastered disc is inserted, or without a grid if a recordable disc is inserted. If the total track number exceeds 25, ▶ appears to the right on number 25 in the music calendar.

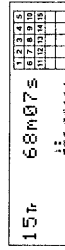
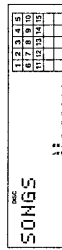

**3** Press ▶▶ (▶▶).

The MD starts playing.

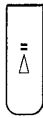

The current track number (minus the Tr indication), track title (if labeled), and elapsed playing time of the current track light up in the display window.

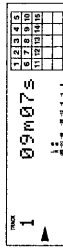
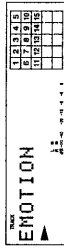
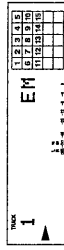

### To stop play momentarily

Press ▶▶ (▶▶) once while the disc is playing.

To cancel pause mode, press ▶▶ (▶▶ or ▶▶) again.

### To stop play

Press ■.

### To eject the disc

Press EJECT ◀.

## Locating a desired track

Use the remote commander to enter the number of the desired track for immediate playback.

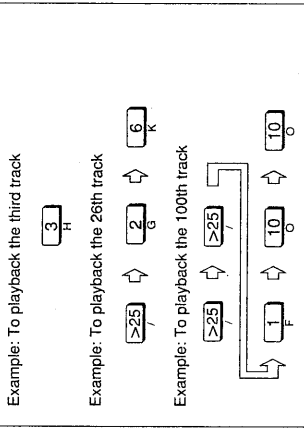

Example: To playback the third track

Example: To playback the 26th track

Example: To playback the 100th track

## Locating the beginning of a track (AMS)

Use the ◀◀ or ▶▶ buttons to quickly find the beginning of a desired track.

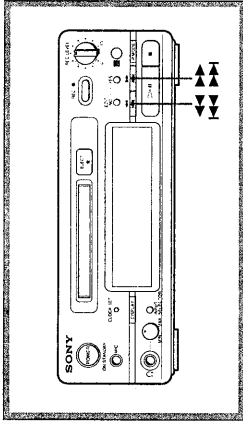

Press to go to previous tracks.



Press to go to succeeding tracks.

Press ▶▶▶ (▶▶▶) once to go to the beginning of the current track.

Press the respective buttons repeatedly to go to the beginning of successive tracks.

If the unit is in pause mode, it will remain in pause mode as it locates the beginning of the desired track.

When the beginning of a labeled track is located, the title appears in the display window.

## To go quickly to the beginning of the last track on the MD

Press ▶▶▶ (▶▶▶) immediately after inserting the disc, or while the disc is in stop mode.

# Playing an MD (Normal Play)

## Locating a desired position (Search)

You can quickly scan an MD either forward or backward during playback to locate a desired position.

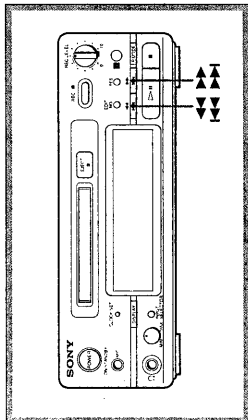

### To forward scan the disc

Hold down **FWD** (▶▶) during playback.

### To backward scan the disc

Hold down **REV** (◀◀) during playback.

Releasing the button causes the unit to play back normally from the desired location.

### To go forward or backward quickly

Hold down **FWD** or **REV** or **FWD** or **REV** in pause mode. No sound is output at this time.

## Displaying the title and remaining playing time of a track

Press the DISPLAY button while playing an MD to display the title and remaining playing time of the current track. ("No Name" is displayed for tracks with no title.) To label a recordable disc and its tracks, see "Labeling Recordings" on page 44.

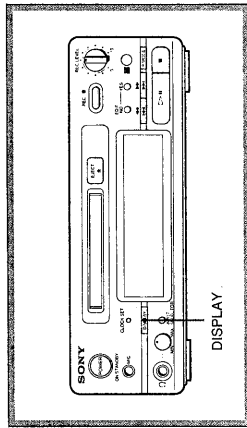

### Press DISPLAY while the current track is playing.

[DISPLAY]

Each press of DISPLAY cycles the display in the following order: remaining track playing time → track name → elapsed playing time

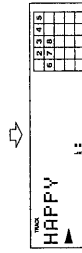
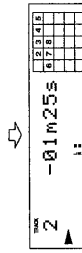
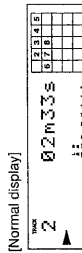

The display window shows up to 12 characters at a time. To see a title of 13 characters or more, press SCROLL on the remote commander. If no title is recorded, "No Name" is displayed, followed by the elapsed playing time. Each press of DISPLAY while the unit is stopped cycles the displaying in the following order:  
Total disc playing time → disc name  
For recorded discs:  
Total recorded time → remaining disc playing time → disc name

## Displaying the recording date

If you have set the built-in clock, the date and time of all recordings are recorded and automatically displayed when the disc is played back.

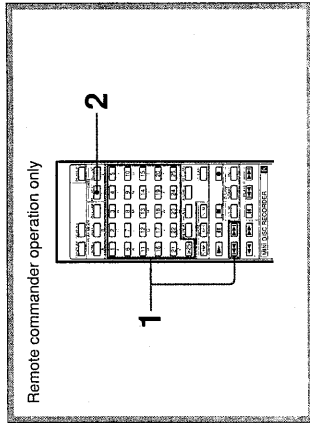

Remote commander operation only

### 1 Locate the desired track.

Press ◀◀ or ▶▶ while the unit is stopped to locate the desired track.



If the unit is playing or in pause, press to enter the track number through the numeric buttons, or ◀◀ or ▶▶ to display the desired track.

### 2 Press DATE RECORDED.

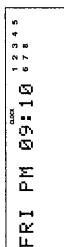
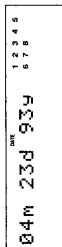

"No Date" is displayed if the built-in clock has not been set or the track was recorded on another unit without a date and time stamp function. The previous display reappears when you press the DATE RECORDED button again or after a few seconds have passed.

## Playing Tracks in Random Order (SHUFFLE Play)

Use shuffle play to play back all tracks on an MD in random order.

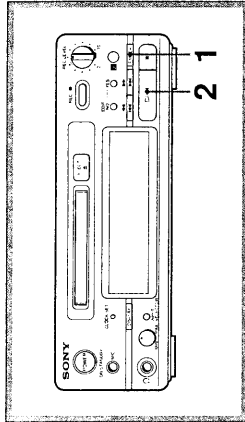

- 1 Press P.MODE (SHUFFLE) repeatedly while the unit is stopped until "SHUFFLE" lights up.

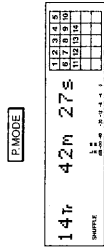

- 2 Press **▶||** (▶). Shuffle play starts.

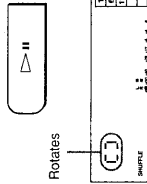

**To go to the beginning of the track during shuffle play**  
Press **◀|▶** (▶|▶) during shuffle play. The current track stops playing and the next randomly selected track begins.  
Press **◀|▶** (◀|◀) to begin playing from the beginning of the current track. Previously played backs cannot be selected again by pressing **◀|▶** (◀|◀).

**To stop shuffle play**  
Press **■**.

**To cancel shuffle play**  
Press P.MODE (CONTINUE) until "SHUFFLE" goes off.

## Playing Tracks in a Specific Order (PROGRAM Play)

Program play allows you to specify the playback order of up to 25 tracks.

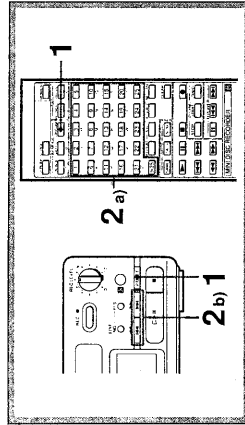

- 1 Press P.MODE (PROGRAM) repeatedly while the unit is stopped until "PROGRAM" lights up.

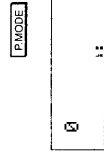

- 2 a) When using the remote commander:

**Enter the desired track number using the numeric buttons.**

The entered track number is stored.  
To program the third track, for example, press 3. The display shows the track number, the order of the specified track, then the total program play time.

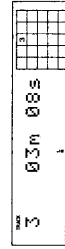
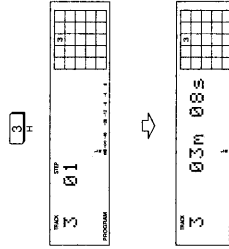

## Playing Tracks in a Specific Order (PROGRAM Play)

**To monitor total program time while programming tracks**  
Perform the following in the place of step 2 above.

- 1 Press **◀|▶** (◀|◀) or **▶|▶** (▶|▶) to select the track. The total program time appears.

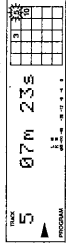

- 2 Press P.MODE (PROGRAM). The selected track is programmed.

**Checking the order of entered tracks**  
Press **◀|▶** (◀|◀) or **▶|▶** (▶|▶) while the unit is in playback or pause mode.

**To erase programmed tracks**  
By pressing CLEAR, you can erase one track at a time starting from the end of the program.

**To stop program play**  
Press **■**.

**To cancel program play**  
Press P.MODE (CONTINUE) until "PROGRAM" disappears.

**To erase a programmed track just entered**  
Press CLEAR, then repeat the programming procedure from step 2 on the previous page.

**To erase all the programmed tracks**  
Press **■** while the unit is stopped, then repeat the programming procedure from step 2 on the previous page.

When programming tracks 26 to 99, press >25 once before pressing the numeric buttons.  
When programming tracks 100 and above, press >25 twice.

**Example:** To program the 26th track

**Example:** To program the 100th track

(Press "10" to enter a zero)

b) When using the front panel:

- 1 Press **◀|▶** or **▶|▶** until the desired track number lights up.

- 2 Press P.MODE. The selected track number is stored.

- 3 **Repeat step 2 to enter other tracks.**  
Each time you enter a track, the total program time is displayed. Up to 25 tracks can be programmed.
- 4 Press **▶||** (▶). Program play starts from the first track of the program.

# Playing Tracks Repeatedly

## Playing tracks repeatedly

The repeat function can be used for repeated playback in normal, shuffle or program play mode.

Remote commander operation only

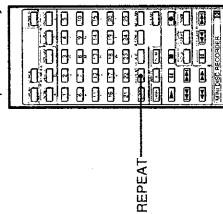

Press REPEAT repeatedly until "REPEAT" lights

up.

All tracks play again.

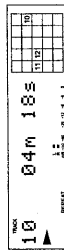

To play back the current track repeatedly, press REPEAT twice.

"REPEAT 1" lights up.

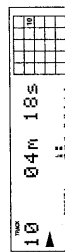

To play tracks repeatedly during shuffle or program play Press REPEAT while in the respective playing mode.

To stop repeated playback Press ■.

To cancel the repeat function Press REPEAT until "REPEAT" disappears. The unit returns to the previous playing mode.

## Playing a specified portion repeatedly (A-B Repeat)

By specifying starting and ending points within a track, you can play back a specified portion repeatedly.

Remote commander operation only

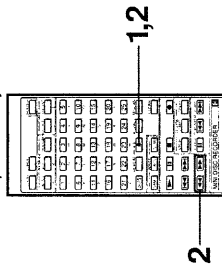

1 While the MD is playing, press A-B at the start (point A) of the portion to be repeated. Point A is stored.

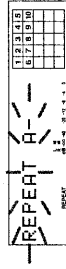

2 Continue playing the track or press ► to the end of the desired portion (point B), then press A-B. Point B is stored, and the specified portion between A and B is played back repeatedly.

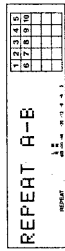
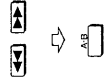

Changing the specified portion Press A-B. Ending point B (point B) changes to starting point A (point A). Repeat step 2 to specify the new ending point (point B).

To cancel A-B repeat playback Press REPEAT to turn off the "REPEAT" indicator.

## Scanning Tracks (Music Scan)

The music scan function automatically plays back the beginning of each track in succession for 6, 10 or 20 seconds, allowing you to quickly check the contents of the MD.

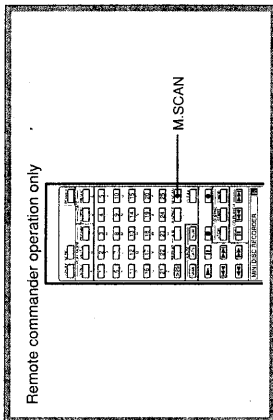

While the unit is stopped, press **M.SCAN**.



When the scanning time appears, each press of **M.SCAN** changes the scanning time to 6, 10, or 20 seconds.

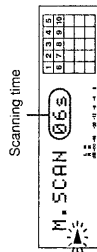

## Inserting Spaces During Playback (Auto Space)

By using the auto space function, a three-second blank space can be inserted after each track to allow the AMS function to work on tapes dubbed from the MD.

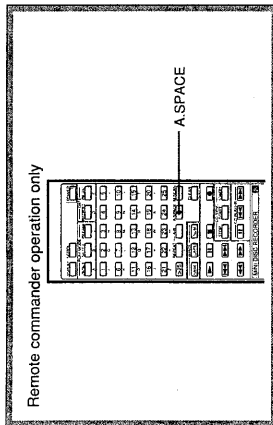

Press **A.SPACE** once. "A.SPACE" lights up.

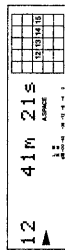

To cancel the auto space function Press **A.SPACE** again to turn off the "A.SPACE" indicator.

### [Notes]

**Sound cut-off may occur at the start of new tracks**  
If the auto space function is activated during material without spaces between tracks, such as symphonies, the insertion of a three-second blank may partially erase material at the start of a new track.

## Recording a MiniDisc

# Recording a Digital Source

### Digital recording

Digital sources connected to the unit through the digital input jack can be recorded onto a recordable MD. When recording from a CD, track numbers on the original are automatically recorded in the original sequence. When recording from other digital sources than a CD, you can add track marks automatically or manually (see page 31). If the inserted disc already contains recorded material, the unit will automatically record the new material at the end of the existing material.

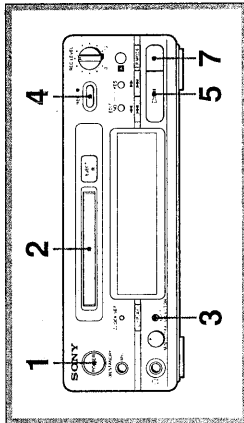

**1** Press **POWER**.



**2** With the label side up and the arrow pointing toward the opening, slide the recordable MD into the disc compartment until the unit grips it.

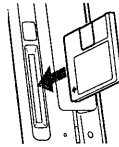

The total number of recorded tracks (Tr) and total time appear. A music calendar showing all recorded track numbers appears without a grid.

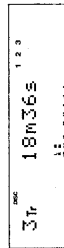

**3** Press **INPUT SELECTOR** until "Digital in" lights up. The previous display appears again after a few seconds.

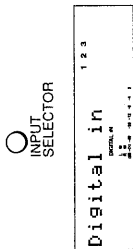

**4** Press **REC** (●). The unit enters recording pause.

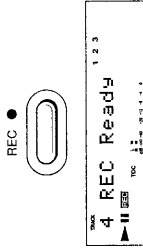

If nothing is connected to the digital input jack, the "Din Unlock" indication appears.

**5** Press **II** (▶ or ◀). Recording pause is canceled and recording starts.

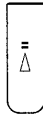

**6** Play the sound source (CD player, etc.) to be recorded. The track number being recorded and elapsed recording time appear.

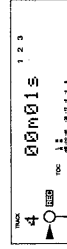

"II" goes off.

**7** Press **■** to stop recording. Recording stops.



## Recording a Digital Source

To check the remaining time on the disc  
Press **DISPLAY**.  
If pressed while the unit is stopped, each press changes the display as follows: total recorded time, remaining time on the disc, disc name.

If pressed while the unit is in recording pause mode ("REC Ready" lights up), the remaining time on the disc appears for a few seconds, followed by the "REC Ready" indication.  
If pressed while the unit is in recording mode: the remaining time on the disc appears.  
Press again to display the elapsed recording time.

### To stop recording temporarily

Press **▶II (▶ or II)**.  
Press **▶II (▶ or II)** again to restart recording.  
Whenever recording is restarted, the track number increases by one. For example, if you stopped recording temporarily while recording the 4th track, recording continues on the 5th track when restarted.

### To eject the disc

Press **EJECT**.

### Notes

If "Protected" appears in the display window  
The disc is write-protected. Close the slot to record on the disc (see page 28).

### MD recording and the Serial Copy Management System

Since your unit uses the SCMS (Serial Copy Management System), MDs recorded through the digital input jack cannot be used to make subsequent copies onto other MDs (see page 50).

When "TOC" flashes in the display window  
Do not jig the unit or pull out the power cord.

### When recording starts

PROGRAM or SHUFFLE play is cancelled.

When recording from a Sony portable MD player or other digital source  
Press **■** on your MD unit to stop recording before stopping playback on the other unit.

If you stop playback on the other unit – or disconnect the optical cable – without stopping the recording first, the contents recorded to that point will not be affected; however, playback on your MD unit will be disabled after the recording is stopped.

If this should occur, reinsert the recorded MD into your MD unit to reactivate the playback function.

## Playing back tracks just recorded

Tracks that have just been recorded can be played back immediately.

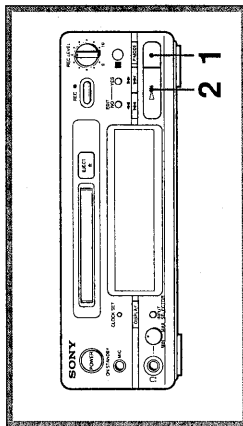

- 1 Press **■** to stop recording.  
The track number just recorded lights up.

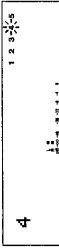

- 2 Press **▶II (▶ or II)**.  
Playback starts from the first of the tracks just recorded.

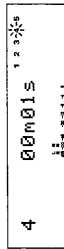

Playing back from the first track of the disc after you have finished recording

- 1 Press **■** to stop recording.
- 2 Press **▶II (▶ or II)**.
- 3 Press **▶II (▶ or II)**.  
Playback starts from the first track of the disc.

### Notes

When recording from digital sound sources  
Track numbers are automatically recorded in the same sequence as the sound source (i.e., based on changes in the emphasis data).

### When dubbing another MiniDisc

Track numbers are automatically recorded in the same sequence as the source disc. However, if the same track is recorded repeatedly (i.e., when played back repeatedly during program play or single-track repeat play), the same track number is recorded each time.

## Recording From the Line (Analog) Input Jack

### Analog recording

If you use a recordable MD that already contains recorded material, the unit will automatically record new material at the end of the existing material, eliminating the need for time-consuming searches.

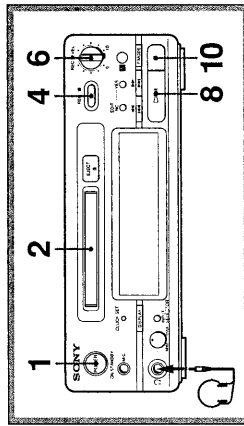

- 1 Press **POWER**.



- 2 With the label side up and the arrow pointing toward the opening, slide the recordable MD into the disc compartment until the unit grips it.

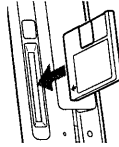

The total number of recorded tracks (Tr) and total time appear. A music calendar showing all recorded track numbers appears without a grid.

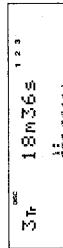

- 3 Press **INPUT SELECTOR** until "Analog in" light up.  
The previous display appears again after a few seconds.

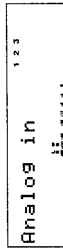

- 4 Press **REC (●)**.  
The unit enters recording pause.

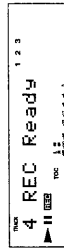

- 5 Play the sound source (CD player, cassette deck, etc.) to be recorded.

- 6 While monitoring through the headphones, adjust the recording level using the **REC LEVEL** control (see page 28).  
Set to the position show below when recording from a Sony DAT deck, CD player or cassette deck.



- 7 Stop the sound source to be recorded.

- 8 Press **▶II (▶ or II)**.  
Recording pause is canceled and recording starts.

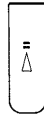

(Continued on next page.)

## Recording From the Line (Analog) Input Jack

(Continued from previous page.)

- 9 Restart the sound source to be recorded.**  
The track number being recorded and elapsed recording time (in minutes and seconds) appear.

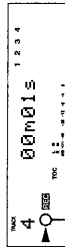

"II" goes off.

- 10 Press [ ] to stop recording.**  
Recording stops.



**To check the remaining time on the disc**  
See page 26.

**To stop recording temporarily**

Press [II] ([II]).  
Press [II] ([II] or [II]) again to restart recording.

**To eject a disc**  
Press EJECT [ ].

### Notes

If "Protected" appears in the display window the disc is write-protected. Close the slot to record on the disc (see "To protect a MiniDisc against accidental erasure" on this page).

When "TOC" flashes in the display window Do not jog the unit or pull out the power cord.

When recording starts PROGRAM or SHUFFLE play is canceled.

### Adjusting the recording level

When recording sound sources through the line (analog) input jack or microphone, the recording level must be adjusted to achieve the optimum recording level.

- 1 Press REC [ ] to put the unit into recording pause.**

- 2 Play the sound source to be recorded.**

- 3 While monitoring the sound through the headphones, adjust the recording level using the REC LEVEL control.**  
Adjust the recording level so the peak level meter reaches its highest point with the least intrusion into the red (OVER) zone.

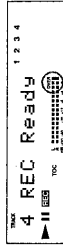

- 4 Press [II] ([II] or [II]) to start recording.**

## Recording From a Microphone

Follow the procedure below to record from a microphone with a stereo mini-plug.

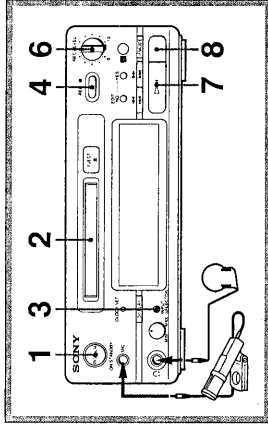

- 1 Press POWER.**



ON/STANDBY

- 2 With the label side up and the arrow pointing toward the opening, slide the recordable MD into the disc compartment until the unit grips it.**

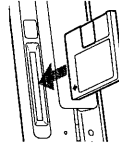

The total number of recorded tracks (Tr) and total time appear. A music calendar showing all recorded track numbers appears without a grid.

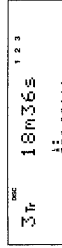

- 3 Press INPUT SELECTOR until "Analog in" lights up.**

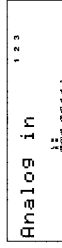

- 4 Press REC [ ].**  
The unit enters recording pause.

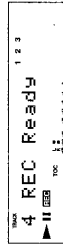

- 5 Use the microphone to pick up the desired sound.**

- 6 Monitoring through the headphones, adjust the recording level with the REC LEVEL control (see page 26).**



(Continued on next page.)

## Recording From a Microphone

(Continued from previous page.)

- 7 Press  $\blacktriangle$  II (  $\blacktriangle$  or II ) to cancel recording pause mode.**  
Recording starts.  
The track number being recorded and elapsed recording time (in minutes and seconds) appear.

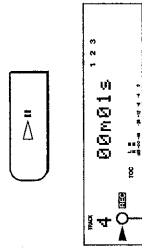

\*II\* goes off.

- 8 Press  $\blacksquare$  to stop recording.**  
Recording stops.



**To check the remaining time on the disc**  
See page 26.

**To stop recording temporarily**  
Press  $\blacktriangle$  II ( II ).  
Press  $\blacktriangle$  II (  $\blacktriangle$  or II ) again to restart recording.

**To eject a disc**  
Press EJECT  $\blacktriangle$ .

Track marking is essentially adding tracks while recording. By adding a track mark (new track number) at desired points, you can quickly locate those points afterwards using the AMS function. Track marks can be added automatically or manually: (1) automatically by the system at points of low signal level, and (2) manually at the points you want.

### Automatic track marking

Press INPUT SELECTOR while the unit is in recording or recording pause mode to display "Level Sync ON".

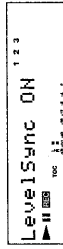

## Track Marking During Recording

### Manual track marking

- 1 Press INPUT SELECTOR while the unit is in recording or recording pause mode to display "Level Sync OFF".**

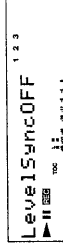

- 2 While recording, press REC  $\bullet$  (  $\bullet$  ) at the point you want to add a track mark.**  
The track number increases by one, and recording on the new track begins (the elapsed recording time indication restarts from zero).

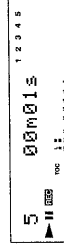
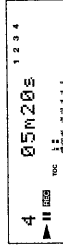

After a track has been recorded, you can divide it further into more tracks to enable material to be quickly located using the AMS function (see "Dividing Recorded Tracks" on page 39).



# CD Synchro-Recording

By connecting your MiniDisc recorder to a Sony CD player or Mini Hi-Fi Component System, you can easily dub CDs onto MDs using the CD synchro buttons on the remote commander. If your unit is connected to a Sony CD player by the optional optical cable through the digital input terminal, tracks are automatically recorded in the same sequence onto the MD regardless of whether "Level Sync ON" or "Level Sync OFF" is on.

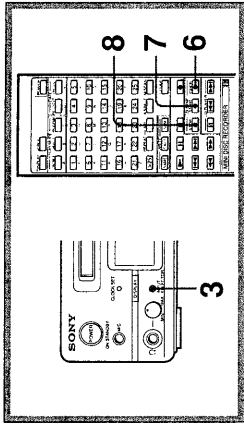

**1** Set the amplifier function selector to CD.

**2** With the label side up and the arrow pointing toward the opening, slide the recordable MD into the disc compartment until the unit grips it.

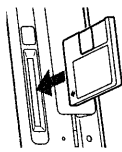

The total number of recorded tracks (Tr) and total time appear. A music calendar showing all recorded track numbers appears without a grid.

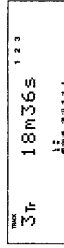

**3** For digital recording, press INPUT SELECTOR until "Digital In" lights up.

For analog recording, press INPUT SELECTOR until "Analog In" lights up, then adjust the REC LEVEL control to the position shown below.

**4** Insert a CD into the CD player.

**5** Select the playback mode (shuffle play, program play, etc.) on the CD player.

**6** Press CD-SYNC/STANDBY. The CD player enters standby, and MD recorder enters recording pause.

**7** Press CD-SYNC/START. The MD recorder starts recording and the CD player starts playback. The track number being recorded and elapsed recording time appear.

**8** Press CD-SYNC/STOP to stop recording. Recording stops.

**To temporarily stop recording**  
Press CD-SYNC/STANDBY or CD PLAYER/II .  
Press CD-SYNC/START or CD PLAYER/II to restart recording.

**To check the remaining time on the disc.**  
See page 26.

**Successive CD synchro-recording of another CD**  
Follow the procedure below in place of step 8.  
1 Press II on the remote commander of the CD player.  
2 Change the CD.  
3 Press II on the remote commander of the CD. Synchro-recording restarts.

**Notes**  
Place the CD player close to this unit. As both the CD player and the unit are controlled by the same remote commander, you may have trouble operating the unit if the units are far from each other.  
When "TOC" flashes in the display window Do not jig the unit or pull out the power cord.

When recording starts PROGRAM or SHUFFLE play is canceled.  
If the CD player does not start playing in step 7 Some CD player models will not start playing when CD-SYNC/START is pressed. Press CD PLAYER/II instead.

# Editing Functions for a Recorded MiniDisc

The editing functions available with your unit allow you to erase, divide, combine and move tracks that have been recorded on an MD. A brief introduction to each function is given on pages 34 and 35.

## Erasing recordings (ERASE Function) (see page 36)

The erase function allows you to erase tracks from a recorded MD easily and instantly. Since erasing merely updates the table of contents (TOC), there is no need to record over existing material as in the case of cassette tapes. Note, however, that once erased, a track cannot be recovered.

After a specific track is erased, the total number of tracks decreases by one, and the remaining tracks are renumbered.

Example: Erasing B

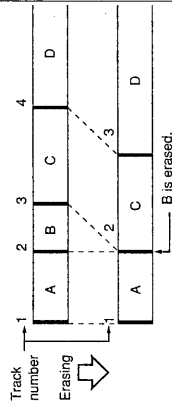

Since tracks following an erasure are renumbered, multiple track erasures should be performed in order of larger to smaller track numbers to prevent the renumbering of tracks not yet erased. For example, when erasing track 2 and 4, erase track 4 before track 2.

## Dividing recorded tracks (DIVIDE Function) (see page 39)

The MD unit records sound sources through the line (analog) input or microphone as a single track on the disc. To randomly access individual tracks or portions within this track, the divide function allows you to create separate tracks for each song or portion. When a track is divided, the total number of tracks increments by one, and the remaining tracks are renumbered.

Additional tracks can also be added while recording through the digital input jack (see "Track Marking During Recording" on page 31).

Example: Dividing track 2 to create a new track for C

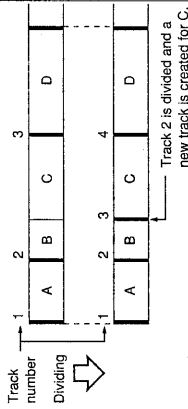

Track 2 is divided and a new track is created for C.

## Combining recorded tracks (COMBINE Function) (see page 41)

The combine function allows you to combine consecutive tracks on a recorded MD. It is useful for combining several songs into a single medley, or several independently recorded portions into a single track. When two tracks are combined, the total number of tracks decreases by one, and the remaining tracks are renumbered.

Example: Combining B and C

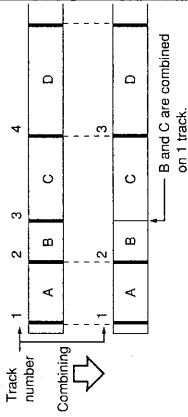

B and C are combined on 1 track.

## Moving recorded tracks (MOVE Function) (see page 42)

With the move function, you can change the order of any track. After a track is moved, the track numbers following the new position are incremented by one.

Example: Moving tracks

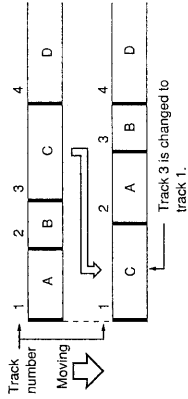

Track 3 is changed to track 1.

## Labeling recordings (TITLE Function) (see page 44)

Use the title function to create titles for your recorded discs and tracks. Titles — which may consist of uppercase and lowercase letters, numbers, symbols and spaces — appear in the display window during operation.

# Erasing Recordings (ERASE Function)

If your recorded MD has been divided into tracks, you can use the procedure below to erase specific tracks easily and instantly. Note, however, that once erased, a track cannot be recovered.

## Erasing a single track

You can erase a track while the unit is in stop, playback or pause mode simply by specifying its respective track number.

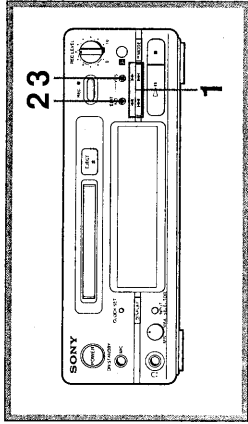

- 1 Press **◀▶** or **▶▶** (◀◀, ▶▶) or numeric buttons) until the track number to be erased lights up.



Example: Erasing track 4

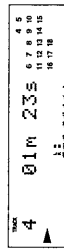

- 2 Press **EDIT** **NO** until "Erase?" lights up.

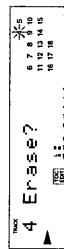

- 3 Press **YES**. "Complete" lights up for a few seconds then disappears, and the specified track is erased. The music calendar decreases by one.

—YES

When erasing a track during playback, the following track begins playing after the erasure is made.

To cancel the ERASE Function Press **EDIT** **NO**, **◀▶**, or **▶▶** to restore the normal display.

### Notes

If the following indication goes on

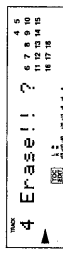

The track has been recorded or edited on another unit and is write-protected. If this indication appears, press **YES** to erase the track.

If the "Protected" indication lights up

The record-protect slot on the disc is open and the specified track cannot be erased. Erase the track after closing the slot.

When "TOC" flashes in the display window

Do not jog the unit or pull out the power cord. After the contents of the recording have been updated, "TOC" lights up. If any changes have been made to an MD, the "TOC" indicator lights up. When **EJECT** or **POWER** is pressed at this time, the "TOC" indicator flashes and the actual contents of the MD are updated.

## Erasing tracks successively

Use the procedure below while the unit is in stop, playback or pause mode to erase consecutive tracks one by one.

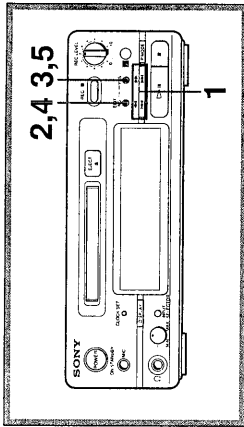

- 1 Press **◀▶** or **▶▶** (◀◀, ▶▶) or numeric buttons) until the first track to be erased lights up.



Example: Erasing track 4

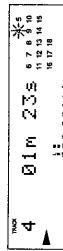

- 2 Press **EDIT** **NO** until "Erase?" lights up.

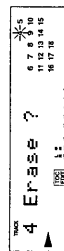

- 3 Press **YES**. "Complete" lights up for a few seconds then disappears, and the specified track is erased. The music calendar decreases by one.

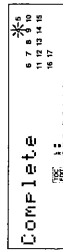

The track following the one just erased starts playing if the unit is in playback mode.

- 4 To erase the next track, press **EDIT** **NO** until "Erase?" lights up.

- 5 Press **YES**. "Complete" lights up for a few seconds then disappears, and the specified track is erased. The music calendar decreases by one.

—YES

- 6 Repeat steps 4 and 5 to erase other successive tracks.

To cancel the ERASE Function

Press **EDIT** **NO** or **▶▶** to restore the normal display.

### Notes

If the "Protected" indication lights up

The record-protect slot on the disc is open and the specified track cannot be erased. Erase the track after closing the slot.

When "TOC" flashes in the display window

Do not jog the unit or pull out the power cord. After the contents of the recording have been updated, "TOC" lights up. If any changes have been made to an MD, the "TOC" indicator lights up. When **EJECT** or **POWER** is pressed at this time, the "TOC" indicator flashes and the actual contents of the MD are updated.

## Erasing Recordings (ERASE Function)

### Erasing a disc

Erasing a recordable MD deletes all recorded tracks. Note, however, that once erased, a track cannot be recovered.

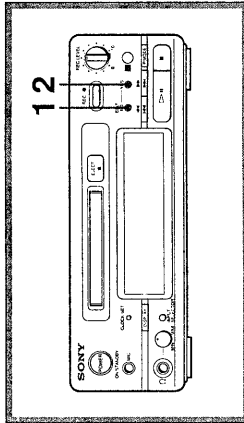

- 1 While the unit is in pause mode, hold down **ERASE** for about a second until "All erase?" lights up.

EDIT  
NO

All Erase ?

- 2 Press **YES**. "Complete" lights up for a few seconds then disappears, and all recorded tracks are erased. The music calendar disappears.

—YES

Complete

To cancel the **ERASE Function**  
Press **ERASE** or **STOP** to restore the normal display.

## Dividing Recorded Tracks (DIVIDE Function)

To be able to randomly access certain portions of a track, you must use the divide function during playback to create separate tracks for each portion.

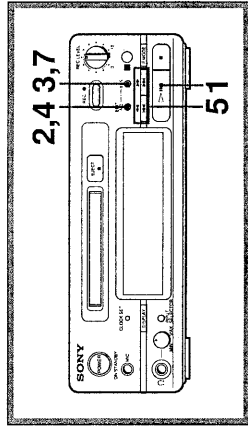

- 1 While playing the MD, press **STOP** to temporarily stop playback at the point where a new track is to be created.

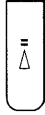

- 2 Press **ERASE** until "Divide?" lights up.

EDIT  
NO

Example: Dividing track 4

4 Divide ?

- 3 Press **YES** when you want to divide the track. The starting portion of the new track plays back repeatedly.

—YES

Rehearsal

Alternating displays.

Position ok ?

- 4 If the starting portion is incorrect, press **ERASE**. (If it is okay, go to step 7.)

EDIT  
NO

Push

- 5 While monitoring the sound, press **STOP** or **STOP** to find the starting point of the new track. The starting portion of the new track is played back repeatedly.

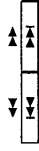

± 02

Rehearsal

Alternating displays.

Position ok ?

- 6 If the starting portion is still incorrect, repeat steps 5 until the correct portion is found.

The starting position can be moved within a range of -128 to +127 steps of about 0.06 second each.

(Continued on next page.)

### Erasing a part of a track

By using the dividing, erasing and combining functions, you can erase specific portions of a track.

Example: Erasing a part of selection A

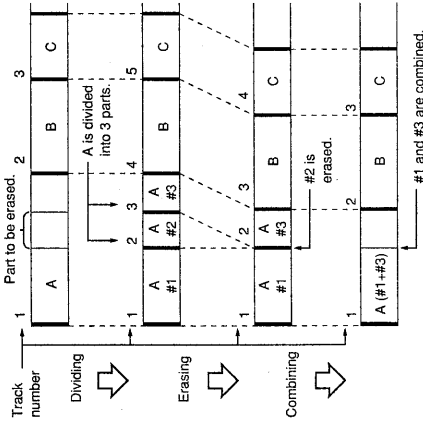

### Notes

If the "Protected" indication lights up  
The record-protect slot on the disc is open and the specified track cannot be edited.  
Edit the track after closing the slot.

When "TOC" flashes in the display window  
Do not jog the unit or pull out the power cord. After the contents of the recording have been updated, "TOC" lights up. If any changes have been made to an MD, the "TOC" indicator lights up. When EJECT or POWER is pressed at this time, the "TOC" indicator flashes and the actual contents of the MD are updated.

## Dividing Recorded Tracks (DIVIDE Function)

(Continued from previous page.)

### 7 Press YES when the correct position is found.

"Complete" lights up for a few seconds then disappears, and the track is divided.

After track division, the newly created track begins playing. The new track will have no track title even if the original track was labeled.

—YES

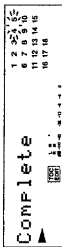

### To cancel the DIVIDE Function

Press **EDIT** or **NO** to restore the normal display.

### To undo a track division

Combine the tracks again (see "Combining Recorded Tracks" on page 41) then redivide the tracks if necessary.

### Changing the step interval in step 5

When "Rehearsal" lights up in step 5, press P.MODE to select  $\pm 1$  for a step interval of  $\pm 0.06$  second, or  $\pm 2$  for a step interval of  $\pm 0.12$  second.

### NOTES

If the "Protected" indication lights up

The record-protect slot on the disc is open and the specified track cannot be divided. Divide the track after closing the slot.

When "TOC" flashes in the display window

Do not jog the unit or pull out the power cord. After the contents of the recording have been updated, "TOC" lights up. If any changes have been made to an MD, the "TOC" indicator lights up. When EJECT or POWER is pressed at this time, the "TOC" indicator flashes and the actual contents of the MD are updated.

## Combining Recorded Tracks (COMBINE Function)

The combine function allows you to combine consecutive tracks on a recorded disc during stop, playback or pause mode.

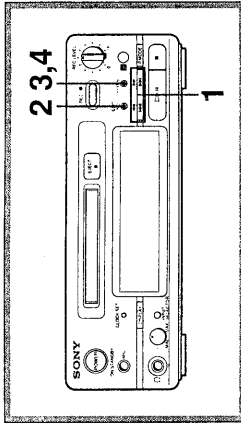

### 1 Press **2** or **3** until the second track of the two to be combined lights up.

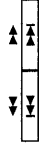

Example: Combining tracks 3 and 4

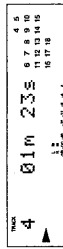

### 2 Press **EDIT** until "Combine?" lights up.

EDIT  
NO

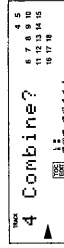

### 3 Press YES.

The portion where the two tracks will join (i.e., the end of the first track and the beginning of the second track) repeatedly plays back.

—YES

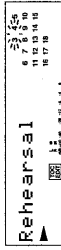

Alternating displays.

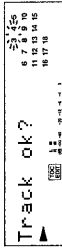

### 4 Verify the tracks, then press YES.

"Complete" lights up for a few seconds then disappears, and the tracks are combined. The music calendar decreases by one. If both of the combined tracks have track titles, the title of the second track is erased (as well as other information such as the recording date).

—YES

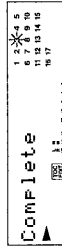

### To cancel the COMBINE Function

Press **EDIT**, **NO**, or **2** to restore the normal display.

### To undo a track combination

Divide the tracks again (see "Dividing Recorded Tracks" on page 39), then repeat the combine function with the correct tracks if necessary.

## Combining Recorded Tracks (COMBINE Function)

### Notes

The following indication lights up

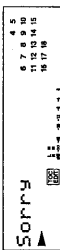

The specified tracks cannot be combined. Extensive editing of the same track may render it impossible to combine with another track. This is due to the technical limitation of the MD system and is not a mechanical error.

### If the "Protected" indication lights up

The record-protect slot on the disc is open and the specified track cannot be combined. Combine the track after closing the slot.

### When "TOC" flashes in the display window

Do not log the unit or pull out the power cord. After the contents of the recording have been updated, "TOC" lights up. If any changes have been made to an MD, the "TOC" indicator lights up. When EJECT or POWER is pressed at this time, the "TOC" indicator flashes and the actual contents of the MD are updated.

## Moving Recorded Tracks (MOVE Function)

Use this function to change the order of specific tracks during stop, playback or pause mode. After moving a track, track numbers following the new track position increment by one.

Example: Moving track 3 to track position 5

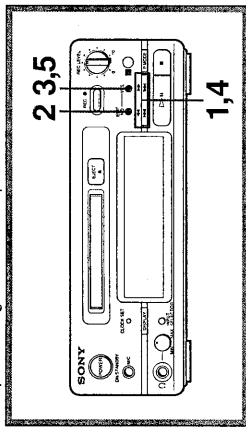

- 1 Press **←** or **→** (**←**, **→**) or numeric buttons) until the track to be moved lights up. Number of track to be moved lights up.



- 2 Press **EDIT** until "Move?" lights up.

EDIT  
NO—

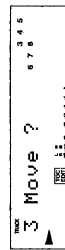

- 3 Press **YES**.

The number of the track to be moved and the new track position lights up.

—YES

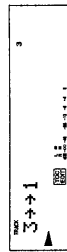

- 4 Press **←** or **→** (**←**, **→**) or numeric buttons) to specify the new track position.

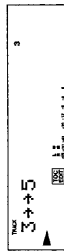

- 5 Press **YES**.

"Complete" lights up for a few seconds then disappears, and the moving procedure is completed. The moved track begins playing back if the unit is in playback mode.

—YES

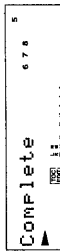

# Labeling Recordings (TITLE Function)

Use the title function to create titles for your recorded discs and tracks. Titles — which may consist of up to 100 uppercase and lowercase letters, numbers and symbols for a maximum of about 1,700 characters per disc — appear in the display window during MD operation.

## Labeling a track

Use this function during playback, pause or recording mode to label a track.

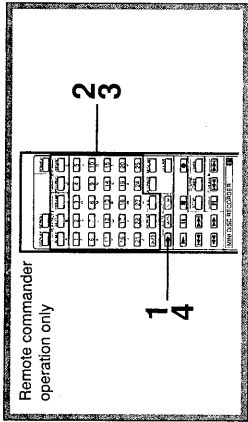

- 1 Press **NAME** while playing back, pausing or recording the track to be labeled. A flashing cursor appears.

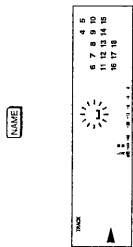

- 2 Enter one character at a time using the character buttons.



Entering the letter "D"

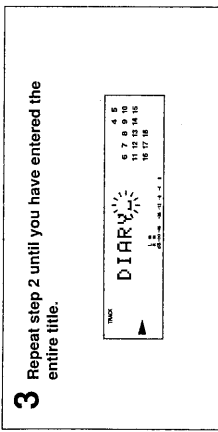

- 3 Repeat step 2 until you have entered the entire title.

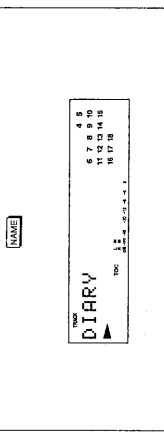

## Entering lowercase letters

- 1 Press **CAPS** until "Selected abc" lights up.
- 2 Enter the desired characters.

## Entering uppercase letters

- 1 Press **CAPS** until "Selected ABC" lights up.
- 2 Enter the desired characters.

## Entering numbers

- 1 Press **NUM** until "Selected 123" lights up.
- 2 Enter the desired numbers.

## Entering uppercase or lowercase letters again

- 1 Press **CAPS** or **NUM** until "Selected ABC" or "Selected abc" lights up.
- 2 Enter the desired characters.

## Entering symbols ( \* , ? , Y , etc.)

- 1 Press **←** or **→** on the remote commander to select the desired character.
- 2 Press **↔** ( **▶▶** ).

## If you enter the wrong character

- 1 Press **←** or **→** to move the flashing cursor under the character to be corrected.

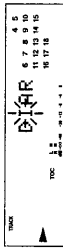

- 2 Press **CLEAR** to erase the incorrect character, then enter the correct letter.

## To cancel the title function

Press **■**.

## Making a correction after entering a title

- 1 Press **NAME** while playing back or pausing the respective track. The current track title lights up.
- 2 To enter an entirely new title, hold down **CLEAR** until the current track title is erased, then enter the new track title. To correct a part of the track title, use the same procedure described in "If you make a mistake" above.
- 3 Press **NAME**.

## Erasing all track titles on a disc

- 1 Hold down **EDIT** on the unit for about one second while the unit is stopped until "All Erase?" lights up.
- 2 Press **NO** again until "Name Erase?" lights up.
- 3 Press **YES**.

## Notes

If the "Protected" indication lights up

The record-protect slot on the disc is open and the specified track cannot be labeled. Label the track after closing the slot.

## When "TOC" flashes in the display window

Do not plug the unit or pull out the power cord. After the contents of the recording have been updated, "TOC" lights up. If any changes have been made to an MD, the "TOC" indicator lights up. When **EJECT** or **POWER** is pressed at this time, the "TOC" indicator flashes and the actual contents of the MD are updated.

## Labeling a disc

Remote commander operation only

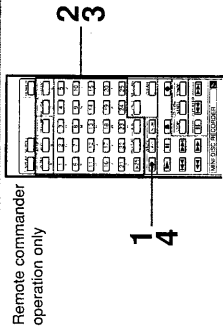

- 1 Insert the disc to be labeled.

- 2 Press **NAME** while the unit is stopped. A flashing cursor appears.

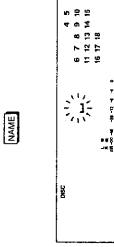

- 3 Enter one character at a time.



Entering the letter "D"

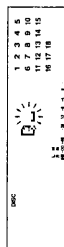

(Continued on next page.)

## Labeling Recordings (TITLE Function)

(Continued from previous page.)

- 4 Repeat step 3 until you have entered the entire title.**

- 5 Press NAME again.**

The entered title appears from the leftside of the display window and the disc labeling procedure is completed.

NAME

### Entering lowercase letters

- 1 Press CAPS until "Selected abc" lights up.
- 2 Enter the desired characters.

### Entering uppercase letters

- 1 Press CAPS until "Selected ABC" lights up.
- 2 Enter the desired characters.

### Entering numbers

- 1 Press NUM until "Selected 123" lights up.
- 2 Enter the desired numbers.

### Entering uppercase or lowercase letters again

- 1 Press CAPS or NUM until "Selected ABC" or "Selected abc" lights up.
- 2 Enter the desired characters.

### Entering symbols (\*, ?, ., etc.)

- 1 Press ◀ or ▶ on the remote commander to select the desired character.
- 2 Press ⏪ (▶▶).  
The following symbols can be used on your unit: ! " # \$ % & ' ( ) \* + , - . / : ; < > ? @ [ \ ] ^ \_ ` { | } ~  
However, the display of the [ \* ] [ { ] ~ symbols may not be supported on certain models of MD player units.

The following table explains the various messages that appear in the display window.

Message	Meaning
Blank Disc	A new (blank) or erased disc has been inserted.
Cannot Copy	An attempt was made to make a second copy from a digitally dubbed MD (see page 50).
Cannot EDIT	An attempt was made to edit the disc during PROGRAM or SHUFFLE play or the inserted disc contains Japanese ideograms.
Disc Error	The disc is abnormal (scratched or missing a TOC).
Disc Full	The disc is full (see "System Limitations").
Impossible	An attempt was made to combine tracks while playing back the first track.
Name Full	The titling capacity of the disc has reached its limit (about 1,792 characters).
No Disc	There is no disc in the unit.
No Track	The inserted disc has a disc title but no tracks.
Protected	The inserted disc is record-protected.
Retry	The first recording attempt failed due to a disturbance or scratch on the MD, and a second recording is being made.
Sorry	An attempt was made to combine tracks that cannot be combined.
TOC Reform?	The TOC has become almost full due to repeated editing operations. Press YES to reform the TOC for a possible increase in recording time. Press NO to bypass the reform process and turn off the message.

## System Limitations

The recording system in your MiniDisc recorder is radically different from those used in cassette and DAT decks and is characterized by the limitations described below. Note, however, that these limitations are due to the inherent nature of the MD recording system itself and not to mechanical causes.

**"Disc Full" lights up even before the disc has reached the maximum recording time (60 or 74 minutes)**  
When 255 tracks have been recorded on the disc, "Disc Full" lights up regardless of the total recorded time. More than 255 tracks cannot be recorded on the disc.

**"Disc Full" lights up before the maximum number of tracks is reached**  
Fluctuations in emphasis within tracks are sometimes interpreted as track intervals, incrementing the track count and causing the "Disc Full" indication to light up.

**The remaining recording time does not increase even after erasing numerous short tracks**  
Tracks of under 8 seconds in length are not counted and so erasing them may not lead to an increase in the recording time.

**Some tracks cannot be combined with others**  
Track combination may become impossible when tracks are edited.

**The total recorded time and the remaining time on the disc may not total the maximum recording time (60 or 74 minutes)**  
Recording is done in minimum units of 2 seconds each, no matter how short the material. The contents recorded may thus be shorter than the maximum recording capacity. Disc space may also be further reduced by scratches.

**Tracks created through editing may exhibit sound dropout during search operations.**

**Track numbers are not recorded correctly**  
Incorrect assignment or recording of track numbers may result (1) when CD tracks are divided into several smaller tracks during digital recording, or (2) when certain CDs are recorded with both the "LevelSync ON" indication and automatic track marking function on.

**"TOC Reading" indication appears for a long time**  
If the inserted recordable disc is brand new, the "TOC Reading" indication appears on the display longer than those that have been used.

**Your MiniDisc recorder is designed as a Hi-Fi stereo system and cannot be used to play back monaural format MDs.**

\* Seventy-four-minute recordable discs will be available in the spring of 1993.



## SECTION 2 DISASSEMBLY

### 2-1. CASE AND FRONT PANEL

Note: Follow the disassembly procedure in the numerical order given.

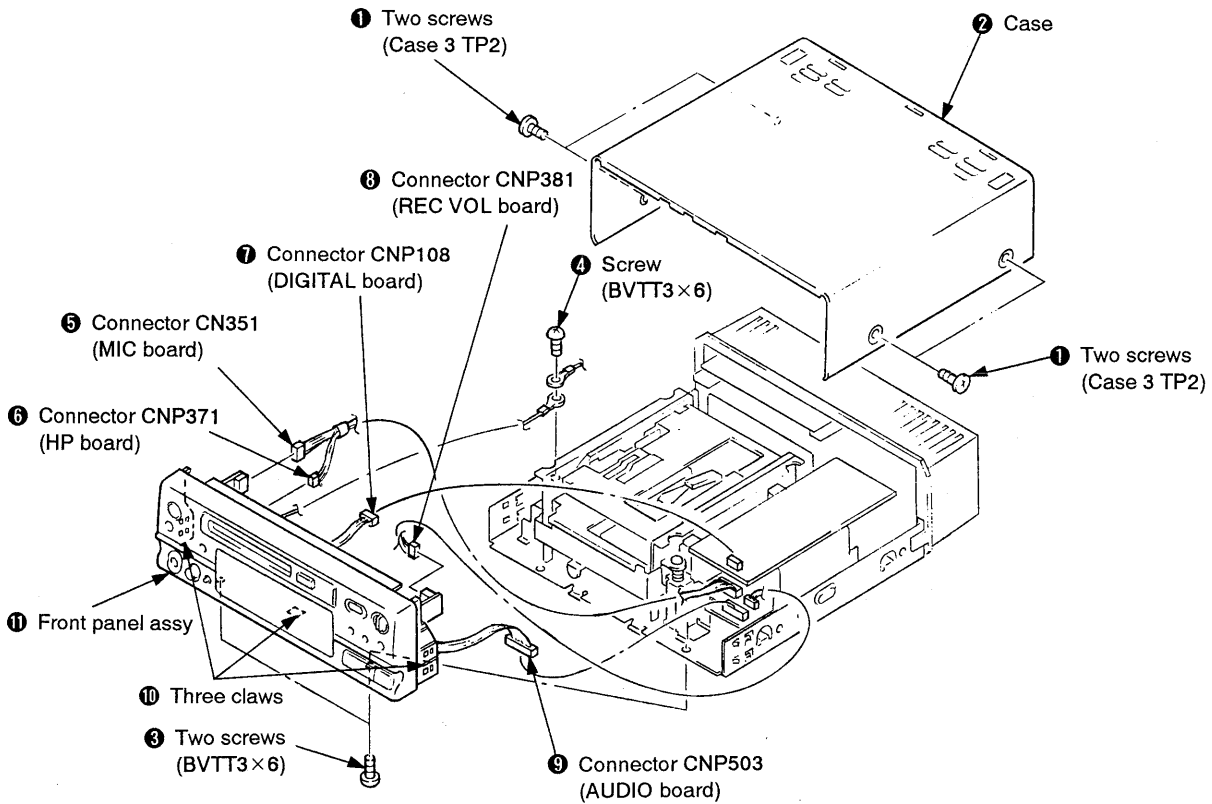

### 2-2. REC VOL BOARD AND DISP BOARD

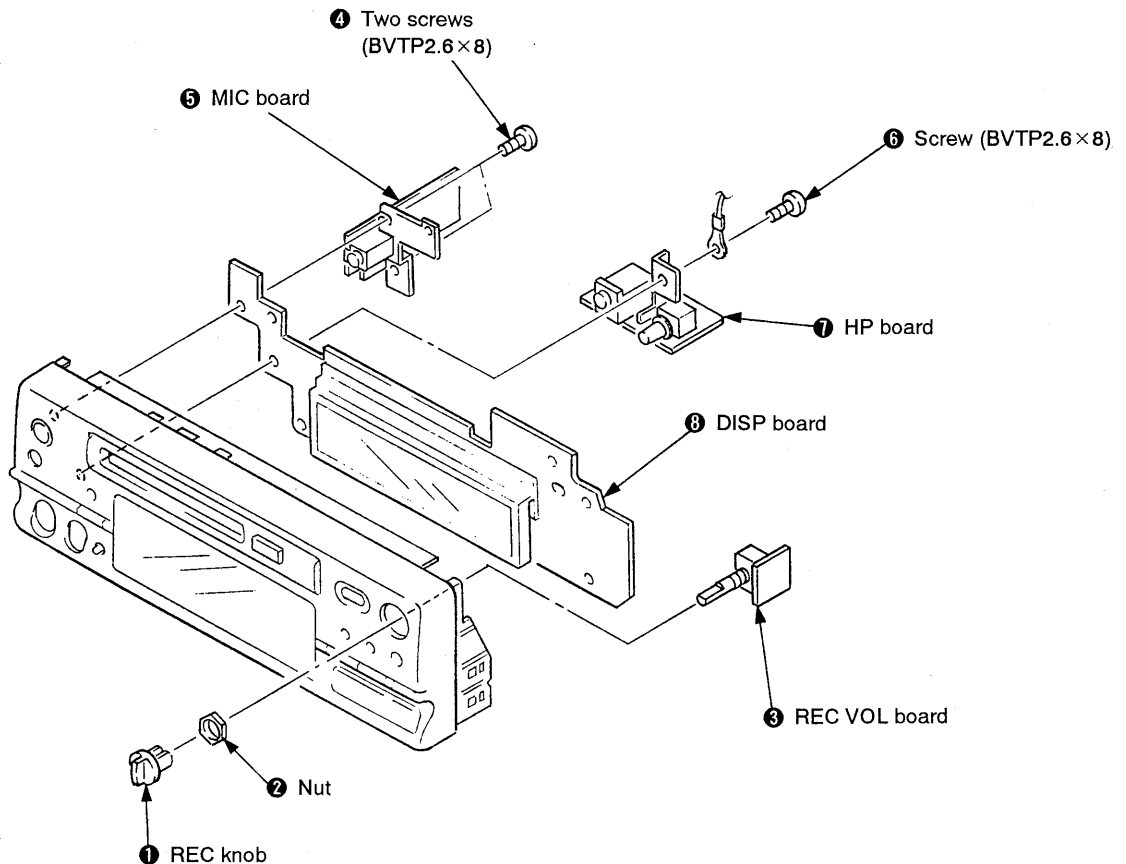

### 2-3. DIGITAL BOARD

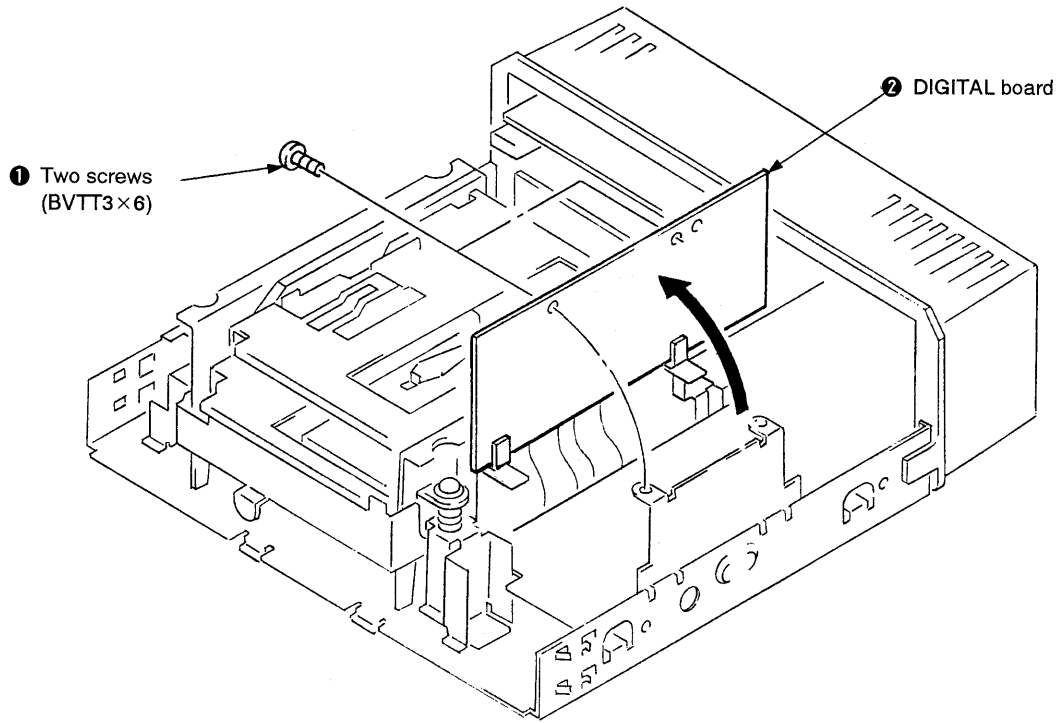

### 2-4. BACK PANEL

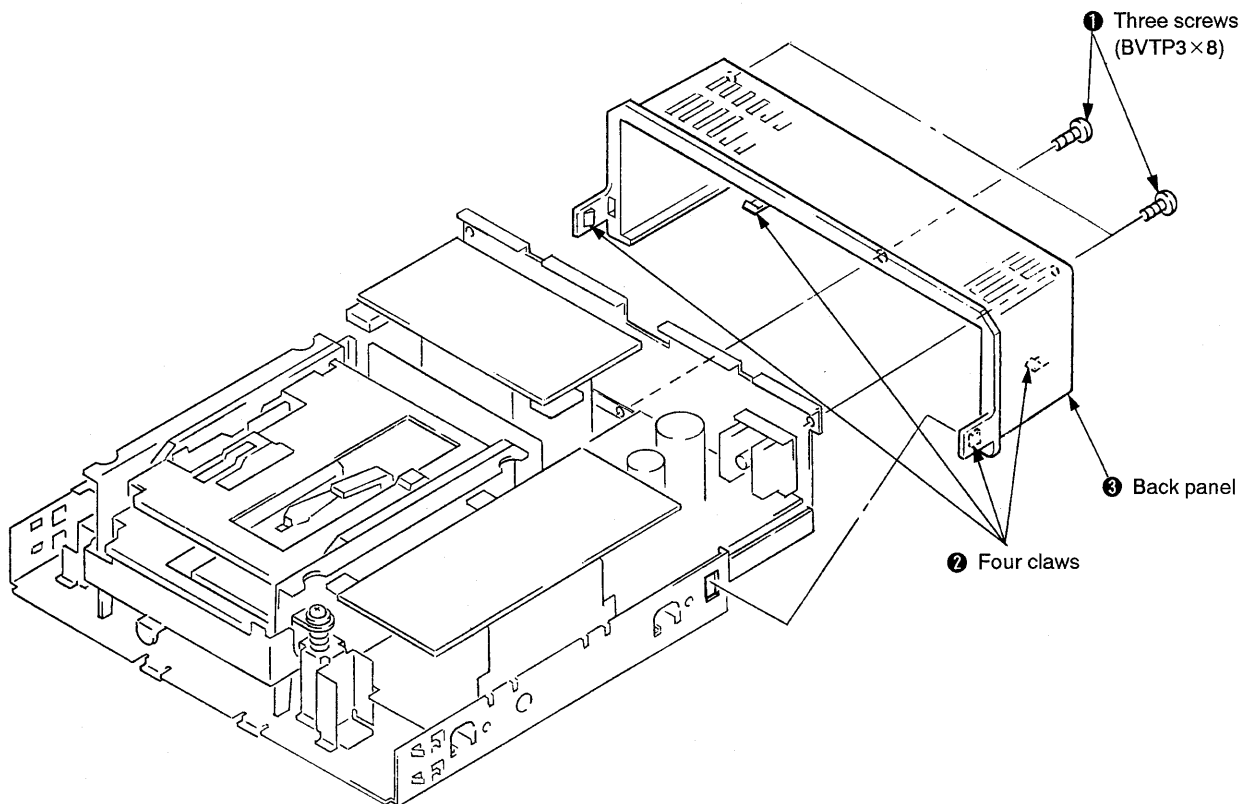

## 2-5. POWER TRANSFORMER

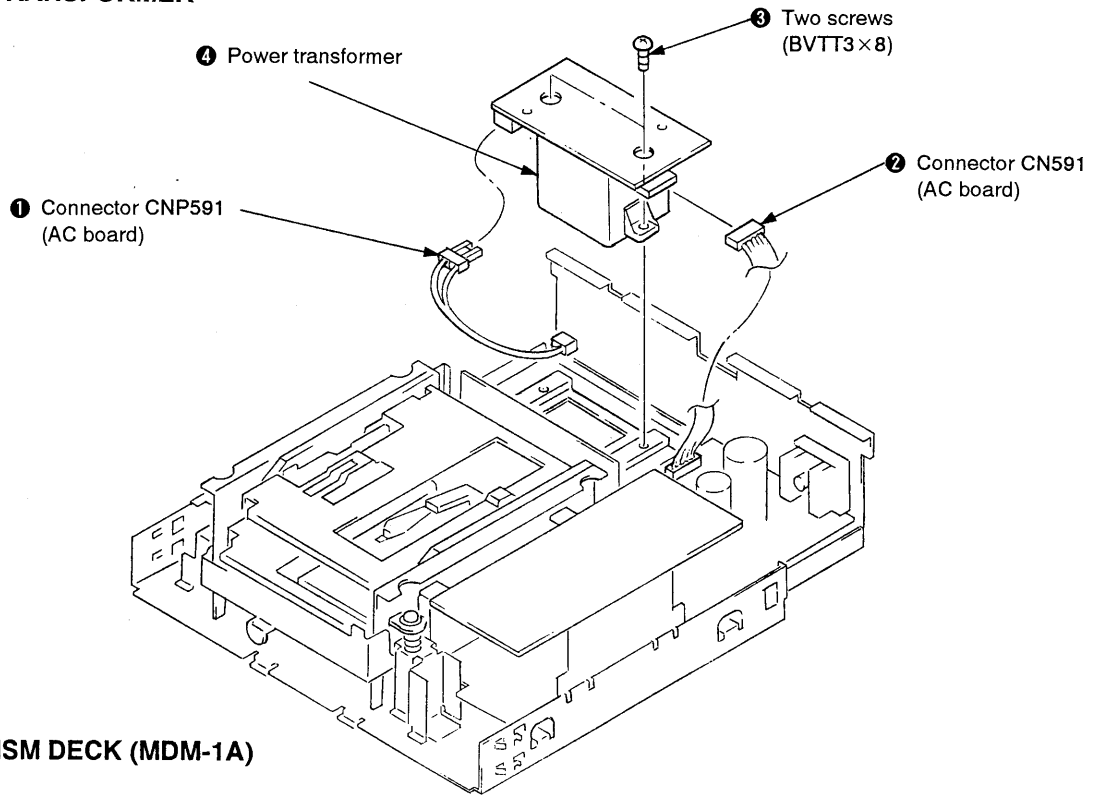

## 2-6. MECHANISM DECK (MDM-1A)

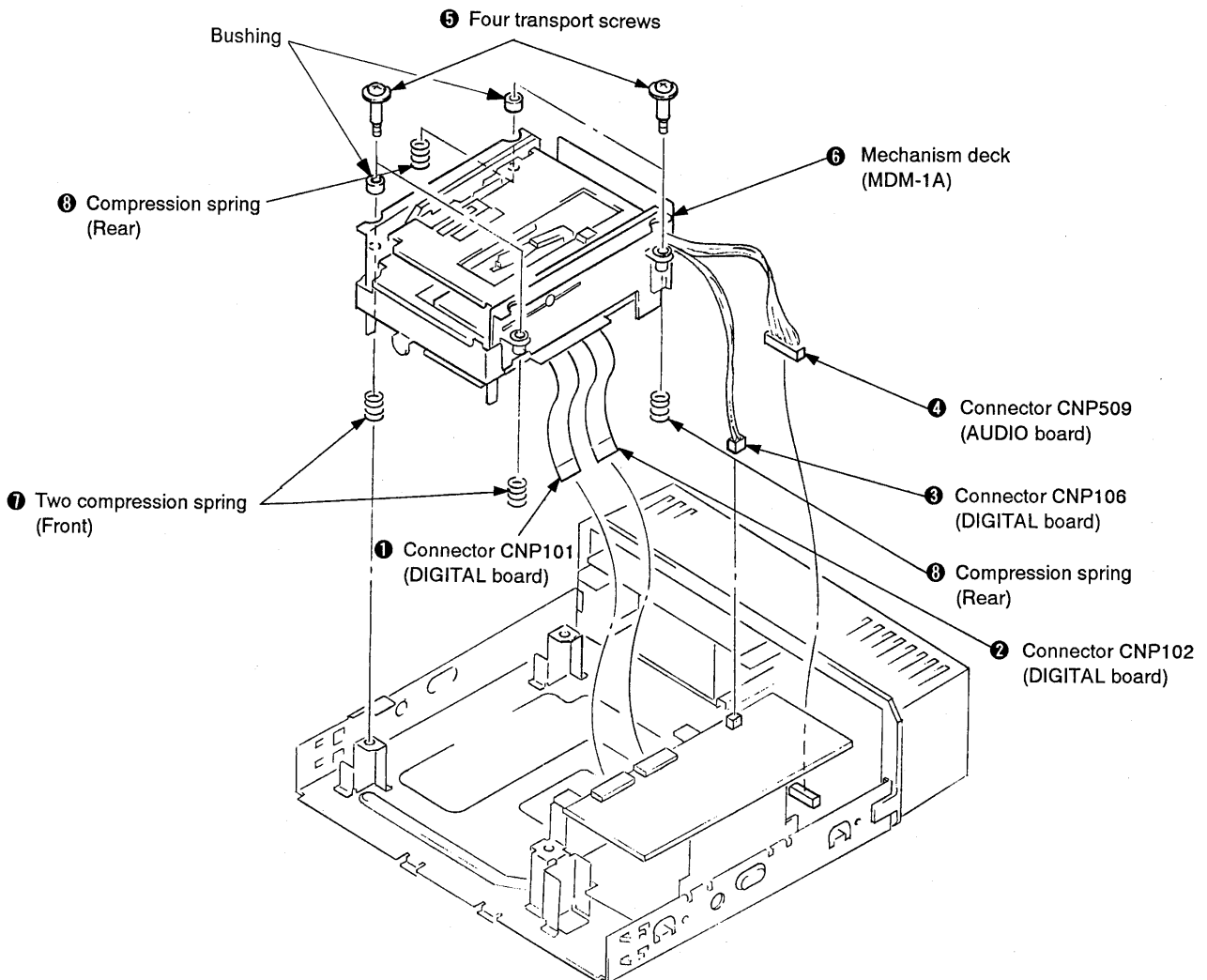

## 2-7. RF BOARD

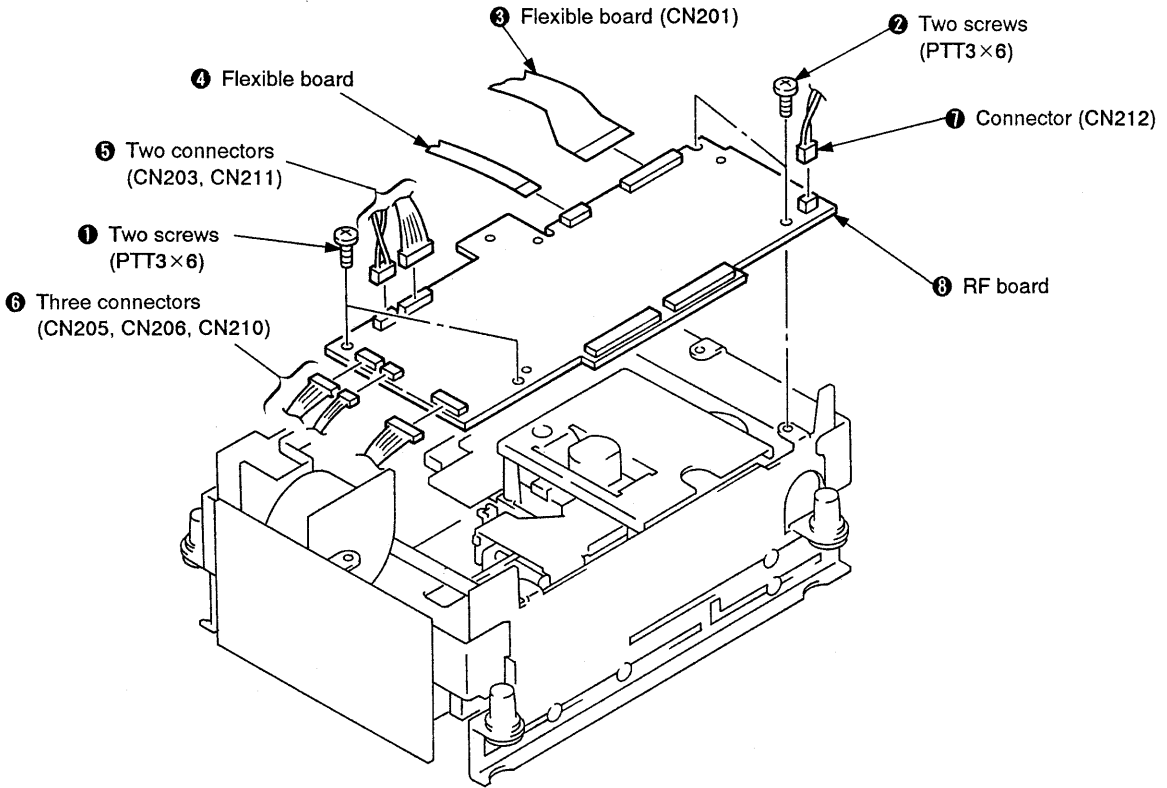

## 2-8. BASE UNIT (MBU-1A)

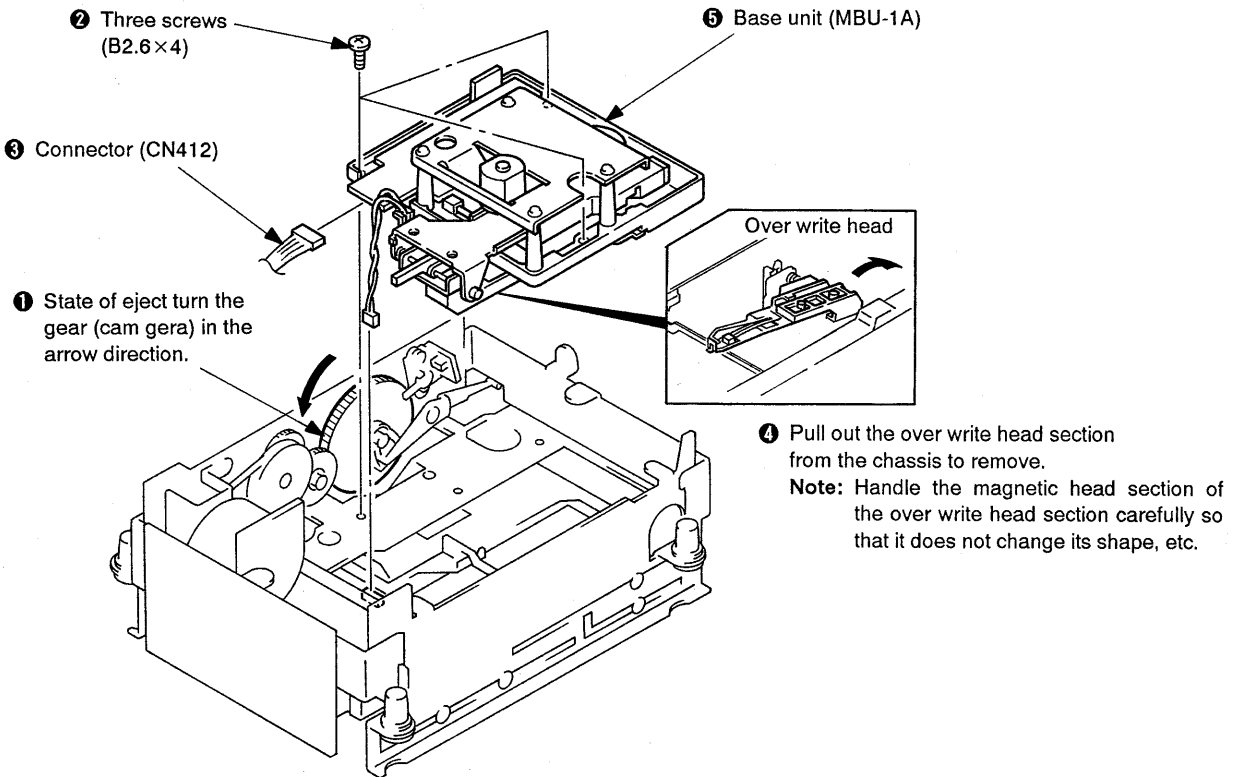

## 2-9. LOADING MOTOR ASSY

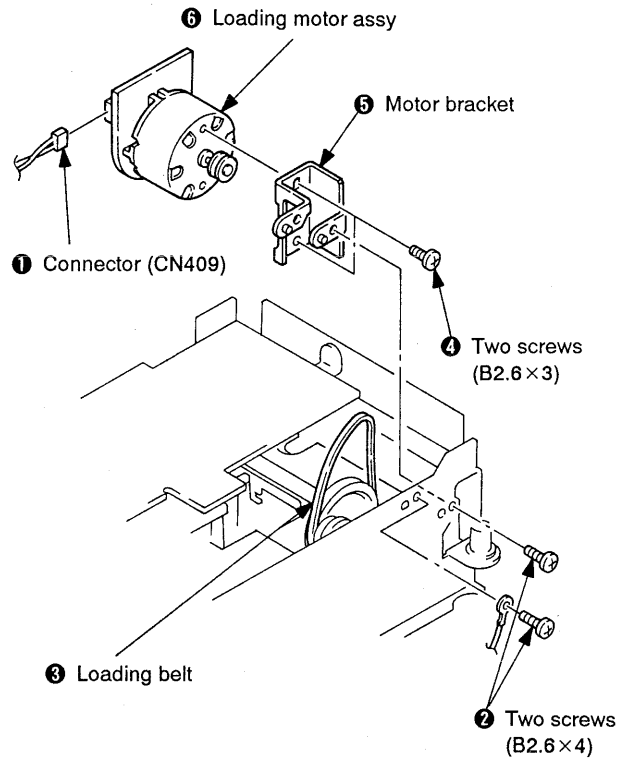

## 2-10. SLED MOTOR

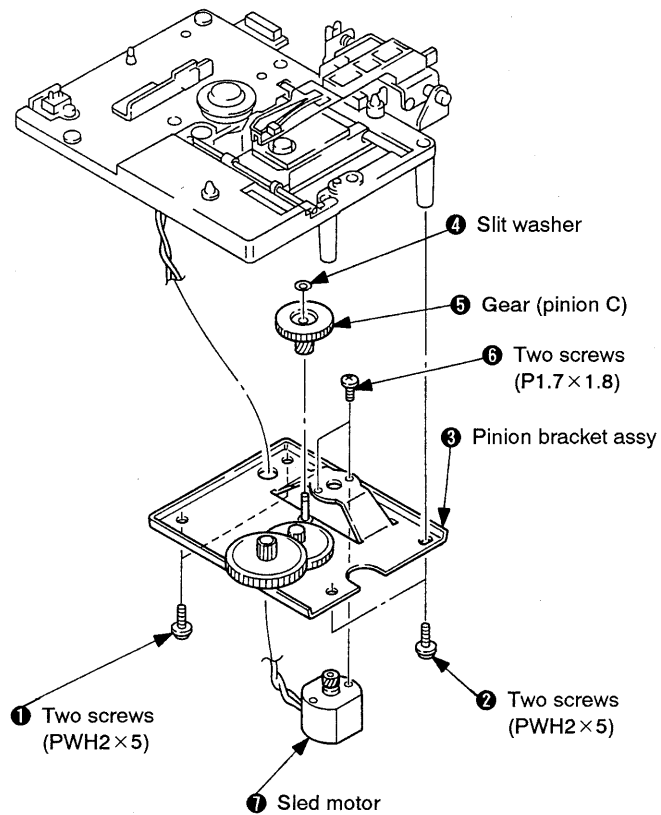

2-11. MINI DISC DEVICE (KMS-140B)

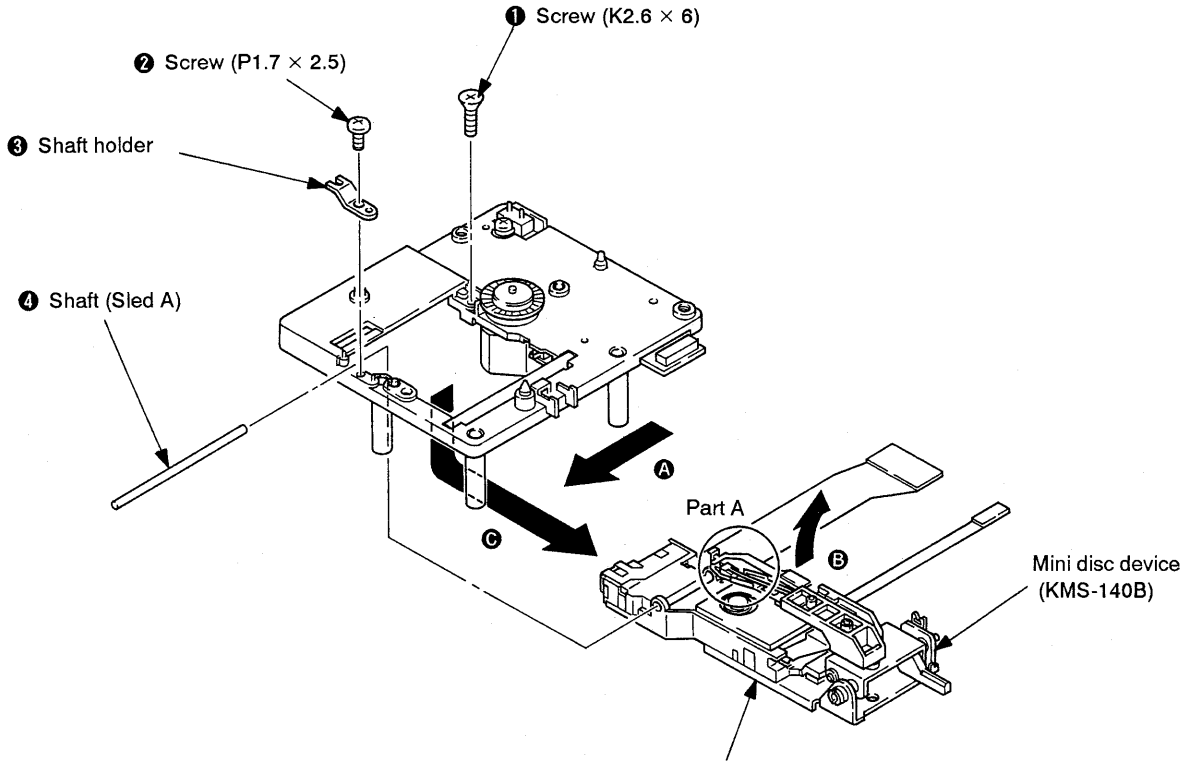

- ⑤ Slide the device in arrow direction **A**.
- ⑥ Lift up the over write head section slightly in arrow direction **B** and remove the mini disc device in arrow direction **C**.

**Note:** Handle the magnetic head section (part A) of the over write head section carefully so that it does not change its shape, etc.

## SECTION 3 IC PIN FUNCTIONS

### IC103 EFM/ACIR ENCODER/DECODER (CXD2525R)

\* (3) of I/O is state output and (A) is analog output.

Pin Name	Signal Name	I/O	Function
1	MDP	O (3)	Spindle motor servo control
2	MDS	O (3)	Spindle motor servo control
3	EFMI	I	Playback EFM input
4	ASY	O	Playback EFM full-swing output
5	LOCK	O	Spindle servo (CLV) lock state monitor. Locks at "H".
6	VCOO	O	EFM decoder analog PLL oscillation output (196Fs=8.6436 MHz)
7	VCOI	I	EFM decoder analog PLL oscillation input (196Fs=8.6436 MHz)
8	TEST1	I	Test pin. Normally GND.
9	PDO	O (3)	EFM decoder analog PLL phase comparison output
10	VSS	—	Digital GND
11	EFMO	O	EFM output during recording
12	ATER	O	ADIP CRC flag output. "H" when error.
13	CNIN	I	Track jump number count signal input
14	SENS	O (3)	Internal status output pin for the serial bus address
15	SYPL	I	SQSY, ADSY, DQSY, MQSY polarity switching input pin. Active high when "H".
16	FILO	O (A)	Digital PLL master PLL filter output
17	FILI	I	Digital PLL master PLL filter input
18	PCO	O (3)	Digital PLL master PLL phase comparison output
19	AVSS	—	Analog GND
20	CLTV	I	Digital PLL master PLL VCO control voltage input
21	AVDD	—	Analog power supply
22	XRST	I	System reset input. Active low
23	REC	I	Decoder when "L" and encoder when "H"
24	TEST8	I	Test pin. Normally GND
25	SCLK	I	Serial bus clock input
26	XLAT	I	Serial bus latch input
27	SWDT	I	Serial bus writing data input
28	SRDT	O (3)	Serial bus reading data output
29	ADSY	O	ADIP sync output
30	SQSY	O	Sub code Q sync output
31	VDD	—	Digital power supply
32	DQSY	O	Sync (SCOR) output of sub code Q of the digital in U-bit CD format
33	TEST7	O	Open
34	DTI	I	Recording audio signal input
35	DTO	O (3)	Playback audio signal output. High impedance during recording
36	C2PO	O	PLAyback: C2PO. Digital REC: D, In-VFLAG. Analog REC: 0
37	BCK	O	2.8224 MHz output (MCLK system)
38	XBCK	O	BCK reverse output (MCLK system)
39	LRCK	O	44.1 kHz (=Fs) (MCLK system)
40	WDCK	O	88.2 kHz (MCLK system)

Pin Name	Signal Name	I/O	Function
41	FS4	O	176.4 kHz (MCLK system)
42	GTOP	O	Opens the sync protection window when "H" (INPUT EFM SYNC monitor output)
43	XUGFS	O	Unguarded frame sync at "L" (INPUT EFM SYNC monitor output)
44	XPLCK	O	EFM decoder PLL clock output (98Fs=4.3218MHz)
45	GFS	O	Frame sync OK at "H" (INPUT EFM SYNC monitor output)
46	EPDO	O (3)	EFM encoder external PLL phase comparison output. Freq.: low → "H"
47	RFCK	O	7.35 kHz output (MCLK system)
48	EVCI	I	EFM encoder external PLL oscillation input (196 Fs=8.6436 MHz)
49	EVCO	O	EFM encoder external PLL oscillation output (196 Fs=8.6436 MHz)
50	VSS	–	Digital GND
51	MCLK	O	22.579 MHz output. Duty will not be protected.
52	XTAI	I	Crystal oscillation input (512 Fs=22.5792 MHz)
53	XTAO	O	Crystal oscillation output (512 Fs=22.5792 MHz)
54	TEST9	I	Fixed at "L"
55	MVCI	I	Digital-in PLL oscillation input (512 Fs=22.5792 MHz)
56	MVCO	O	Digital-in PLL oscillation output (512 Fs=22.5792 MHz)
57	TEST2	O	Fixed at "Open"
58	DIPD	O (3)	Digital PLL phase comparison output. Freq.: low → "L"
59	RAOF	O	RAM overflow output (Monitor output of decoder)
60	MT3	O	Playback corrected state monitor output
61	MT2	O	Playback corrected state monitor output
62	MT1	O	Playback corrected state monitor output
63	MT0	O	Playback corrected state monitor output
64	WFCK	O	7.35 kHz output (EFM decoder PLL system during playback, EFM encoder PLL system during recording)
65	DIN	I	Digital audio input pin
66	MD2	I	Digital audio out ON/OFF pin. ON when "H"
67	DOUT	O	Digital audio output pin
68	DIDT	O	Audio data output pin of the digital audio input pin
69	DODT	I	16-bit data input pin for the digital audio output
70	DOVF	I	Validity flag input pin for the digital audio
71	VDD	–	Digital power supply
72	TEST3	I	Fixed at "L"
73	TEST4	O	Fixed at "Open"
74	TEST5	I	Fixed at "L"
75	TEST6	I	Fixed at "L"
76	FMCK	I	ADIP reading clock input (6.3 kHz) (TTL Schmidt input)
77	FMDT	I	ADIP data input (TTL Schmidt input)
78	ADFG	I	ADIP carrier signal input (20.05 kHz) (TTL Schmidt input)
79	FSW	O (3)	Spindle motor output filter switching output. "Z" when CLV-P. Others: "L"
80	NON	O	Spindle motor ON/OFF control output. ON when "H"

- Note:**
- XUGFS is a frame sync obtained from the EFM signal and is a negative pulse. Signal before sync protection.
  - PLL is made for XPLCK so that changes in the reversion and falling edge of the EFM PLL clock and the EFM signal match.
  - The GFS signal becomes "H" when the frame sync and interpolation protection timing match.
  - C2PO is a signal which shows the error state of the data.
  - RAOF is a signal generated when the 32K RAM exceeds the  $\pm 4F$  jitter margin.



**IC110 Shockproof Memory Controller (CXD2526Q)**

Pin Name	Signal Name	I/O	Function
1	A14	O	When RMSL is H: SRAM address bus A14. When RMSL is L: WFFUL (Note)
2	A15	O	When RMSL is H: SRAM address bus A15. When RMSL is L: RFEMP (Note)
3	A16	O	When RMSL is H: SRAM address bus A16. When RMSL is L: WFOVF (Note)
4	A17	O	When RMSL is H: SRAM address bus A17. When RMSL is L: WDTM (Note)
5	A18	O	When RMSL is H: SRAM address bus A18. When RMSL is L: ZERO (Note)
6	A19	O	When RMSL is H: SRAM address bus A19. When RMSL is L: MDTSC (Note)
7	A20	O	When RMSL is H: SRAM address bus A20. When RMSL is L: CMPSY (Note)
8	LRCK	I	LRCK input from the EFM encoder/decoder
9	BCK	I	BCK input from the EFM encoder/decoder
10	C2PO	I	C2PO input from the EFM decoder
11	DATA	I/O	Input/output data from the decoder during playback and that to the encoder during recording
12	VSS	—	GND
13	TEST	I	Test pin. Normally fixed at “L”
14	XRST	I	Reset input. Resets when “L”
15	MIN	I	External input monitor signal input pin. Inputs the signal to be monitored
16	SRDT	(HiZ) O	Microprocessor serial data output pin “Hi-z” when the CXD2526 read register is not selected
17	SWDT	I	Microprocessor serial data input pin
18	XSLT	I	Microprocessor serial data latch signal input pin
19	SCK	I	Microprocessor serial data shift lock input pin
20	SCTX	I	Data output enable signal input pin in the recording mode
21	RCPB	I	“L”: Playback mode, “H”: Recording mode
22	WRMN	I	“H”: Write mode, “L”: Monitor mode
23	SBMN	I	“H”: Records the input signal according to the SDCT. “L”: Records according to the DCT
24	XINT	O	Interrupting request output pin. “L” when the interrupting status is generated
25	MDSY	O	Input data MD sync detection signal
26	MEMFUL	O	“H” when the main data area is full with data
27	MEMEMP	O	“H” when the main data area is empty
28	UNDER	O	“H” when $RMS < THUND$
29	OVER	O	“H” when $RMS \geq THOVR$
30	ERWR	O	“H” when the data which C2PO is effective is written in the RAM
31	BTOV4	O	“H” when $BCT \geq 400$ (Hex)
32	TXST	O	“H” when data is transmitted
33	VDD	—	System power supply
34	BUSY	I/O	“H” when RAM is accessed
35	ZZ2	I	Test signal. Fixed at “L”
36	ZZ1	I	Test signal. Fixed at “L”
37	ZZ0	I	Test signal. Fixed at “L”
38	XALT	O	Data ready or latch signal to CXD2527
39	ADT1	I	Pin for data input from CXD2527
40	ADTO	O	Pin for data output to CXD2527
41	ACK	O	Pin for data input/output clock output to CXD2527
42	AC2	O	Pin for output data C2PO output to CXD2527
43	XRQ	I	Pin for data request signal input from CXD2527

Pin Name	Signal Name	I/O	Function
44	SDCK	I	External sub data I/F shift clock input
45	SBDT	I/O	External sub data I/F data output pin in the playback mode and the data input pin in the recording mode
46	XWT	O	External sub data I/F wait signal. Must not transmit the clock for reading the new data at "L"
47	SRDY	O	External sub data I/F access permission signal. Ignores the clock for sub data R/W if it is transmitted at "H"
48	MCK	O	128 fs output pin
49	F256	O	256 fs output pin
50	XTLO	O	System clock output pin (22.5792 MHz)
51	XTLI	I	System clock input pin (22.5792 Mhz)
52	VSS	–	GND
53	TEST	I	Fixed at "L"
54	RMSL	I	External RAM select pin. "H": SRAM. "L": DRAM
55	ERR	I/O	C2PO input/output pin when EXTC2R is "H"
56	D7	O	SRAM data line D7 when RMSL is "H". Test signal when "L".
57	D4	I/O	RAM data bus D4 when RMSL is "H". Test signal when "L".
58	D0	I/O	RAM data bus D0
59	D1	I/O	RAM data bus D1
60	D3	I/O	RAM data bus D3
61	D2	I/O	RAM data bus D2
62	XCAS	I/O	DRAM $\overline{\text{CAS}}$ output when RMSL is "L". Data bus D6 when "L"
63	XOE	O	RAM output enable
64	A10	O	RAM address bus A10
65	XWE	O	RAM write enable
66	XRAS	I/O	DRAM $\overline{\text{RAS}}$ output when RMSL is "L". Data bus D5 when "H"
67	A11	O	RAM address bus A11
68	A9	O	RAM address bus A9
69	A0	O	RAM address bus A0
70	A1	O	RAM address bus A1
71	A2	O	RAM address bus A2
72	A3	O	RAM address bus A3
73	VDD	O	System power
74	A8	O	RAM address bus A8
75	A7	O	RAM address bus A7
76	A6	O	RAM address bus A6
77	A5	O	RAM address bus A5
78	A4	O	RAM address bus A4
79	A12	O	RAM address bus A12 when RMSL is "H". CS output when "L"
80	A13	O	RAM address bus A13 when RMSL is "H". SYOK output when "L"

**Note:** WFFUL: Becomes "H" when the writing FIFO becomes full.  
RFEMP: Becomes "H" when the reading FIFO becomes empty.  
WFOVF: Becomes "H" when the writing FIFO becomes overflow.  
WDTM: Outputs the window timing inside the D1 clock.  
ZERO: Outputs "H" when BCT is 0.  
MDTSC: Becomes "H" when the input data header selector is 00 to 1F and "L" at other times.  
CMPSY: Interpolation sync timing.

**IC111 MECHANISM MICROPROCESSOR (M38067M8-051P)**

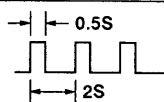
Pin Name	Signal Name	I/O	Function
1 to 3	KEY 2 to KEY 0	I	Not used
4	—	I	Not used
5	DFATT	O	Serial data to the digital filter
6	DFSHIFT	O	Serial clock to the digital filter
7	DFLATCH	O	Latch to the digital filter
8	XLAT	O	Latch to the serial bus
9	SCLK	O	Clock to the serial bus
10	SWDT	O	Data to the serial bus
11	SRDT	I	Data from the serial bus
12	APCREF	O	Reference voltage output of the laser power. Four levels: OFF, CD, MO READ, MO WRITE.
13 to 15	—	I	Not used
16	ADSY	I	ADIP sync. "L" every 13.3 ms. Almost "H".
17	SQSY	I	Sub-code Q sync. "L" every 13.3 ms. Almost "H".
18	DQSY	I	U-bit CD format sub-code Q sync of digital in. "L" every 13.3 ms. Almost "H".
19	SENS	I	Status from the serial bus.
20	MINT	O	Request for temporary interruption of communication with the master microprocessor. The master microprocessor does not send the clock during "H".
21	CLK	I	Communication clock from the master microprocessor
22	TXD	O	Serial data to the master microprocessor
23	RXD	I	Serial data from the master microprocessor
24	XINT	I	Request for interruption from the shock-proof memory controller.
25	JUMP. PULSE	I	Signal from the track-jump detection circuit. 1 pulse is output every 1 track.
26	CNVSS	—	Mode setting pin at power start-up. Always 0V.
27	RESET	I	Reset input. "H" after several hundred ms of "L" after power start-up.
28, 29	—	I	Not used
30	XIN	I	6 MHz clock input
31	XOUT	O	6 MHz clock output
32	VSS	—	GND
33	ARESET	O	Reset output to the ATRAC encoder/decoder
34, 35	—	I	Not used
36	ALLD	O	APCREF/CONSTANT selection. When CD playback power: "L". When MO playback power: "H".
37	RMS	O	Laser modulation selection. When playback power: "L". When stop: "H". When recording power: 
38	LOADIN	O	Loading control. When LOAD IN: "H"
39	LOADOUT	O	Loading control. When LOAD OUT: "H"
40	PIT/GROOVE	I	PIT/GROOVE detection input. "H": Disc for playing and TOC area
41	C. OUT	I	Track number counting signal input
42	DIRC	O	Output pin for the servo IC during 1 track jump
43	AGCTC	O	AGC time constant selection. "L": Focus searching and power selection
44	DFCTSW	O	Defect ON/OFF selection
45	FOK	I	Focus OK signal input

Pin Name	Signal Name	I/O	Function
46	CD/MO	I	CD/MO discrimination signal input
47	RFSW1	O	Disc mode selection. "H": PIT, "L": GROOVE
48	RFSW0	O	Disc mode selection. "H": High reflection rate disc. "L": Low reflection rate disc.
49	MAGUP	O	Not used
50	MGSERVO	O	Not used
51	—	I	Not used
52	CARTRIG	I	Not used
53	DSCPRO	I	REC-proof detection input. "H": Protect
54	RFLCT	I	Disc reflection rate detection input. "H": Low reflection rate disc
55	LIMITIN	I	Limit in switch input. "L": Sled limit in
56	INSW	I	Loading in switch input. "L" at the position where the head descends. Others: "H"
57	OUTSW	I	Loading out switch input. "L" at the position of load out. Others: "H".
58	SLEN	O	Sled servo ON/OFF control. Normally, the LOCK of Pin 72 is output.
59	FBC	O	Focus bias control
60	MNSB	O	Main/sub-data counter selection to the shock-proof memory controller
61	WRMN	O	Write/monitor mode selection to the shock-proof memory controller
62	INSL		Not used
63	EXEC		Not used
64	MUTE	O	Muting output to the digital filter
65	AMUT	O	Line out muting output
66	DIG/ANA	O	ON/OFF selection of the digital in PLL circuit
67	—	I	Not used
68	GFS	I	Guard frame sync input
69	SORS	I	Not used
70	REC	O	Encoder/decoder mode selection to the shock-proof memory controller and EFM/ACIR encoder/decoder "H": Encoder mode
71	SCTX	O	Writing data transmission timing output. Used together with the magnetic field head ON/OFF output.
72	LOCK	I	Spindle lock detection input
73	VCC	—	+5V
74	VREF	—	Maximum output voltage input pin of the 12-pin APCREF
75	AVSS	—	Analog GND
76	CHACK. IN	I	Chucking in switch input. When chucking: "L"
77, 78	—	I	Not used
79	ASY. DISEN	O	Asymmetry ON/OFF control. Other than disc data input: "H"
80	LDON	O	Laser ON/OFF control. When the laser is ON: "H"

**IC301 MASTER MICROPROCESSOR (M38003M6-050P)**

Pin Name	Signal Name	I/O	Function
1, 2	—	I	Not used
3	S/A SW	O	Remote control input/AU BUS input selection. "H": AU BUS input
4	AUBS	O	AU BUS output
5	AUBK	I	AU BUS connection check. "H": The AU BUS is determined to have connected.
6, 7	RMC	I	Remote control, AU BUS input
8 to 11	—	I	Not used
12	MCS	O	Chip select signal to the mechanism microprocessor. "H": Mechanism microprocessor select
13	SCLK	O	Serial clock output
14	SOUT	O	Serial data output
15	SIN	I	Serial data input
16	SRST	I	BUSY signal from the mechanism microprocessor. "H": Mechanism microprocessor communication is BUSY
17	—	I	Not used
18	CN V <sub>ss</sub>	—	GND
19	RST IN	I	Reset input
20	—	I	Not used
21	FLCS	O	Chip select signal to the FL driver. "L": FL driver select
22	XIN	I	5 MHz clock input
23	XOUT	O	5 MHz clock output
24	V <sub>ss</sub>	—	GND
25	RST 0	O	Reset output
26	RELAY	O	Power supply control. "H": When the power is ON
27	SELECT 0	I	Clock display select pin
28	SELECT 1	I	Clock display select pin
29 to 33	—	I	Not used
34	TEST 0	I	Test mode setting pin. "H": Cancels the communication with the mechanism microprocessor
35	TEST 1	I	Test mode setting pin. "H": Key display test mode when the power is ON.
36	TEST 2	I	Test mode setting pin. "H": Clock IC test mode when the power is ON.
37, 38	—	I	Not used
39, 40	KEYS 1, KEYS 0	O	Key scan digit output
41 to 48	KEY 7 to KEY 0	I	Key scan input
49 to 52	A3 to A0	O	Address output to the clock IC
53 to 56	D3 to D0	I/O	Data input/output with the clock IC
57	V <sub>cc</sub>	—	5V
58	RD	O	READ signal to the clock IC. "L": READ
59	WR	O	WRITE signal to the clock IC. "L": WRITE
60	CS	O	Chip select signal to the clock IC. "L": Clock IC select
61 to 64	—	I	Not used

# SECTION 4 DIAGRAMS

## 4-1. CIRCUIT BOARDS LOCATION

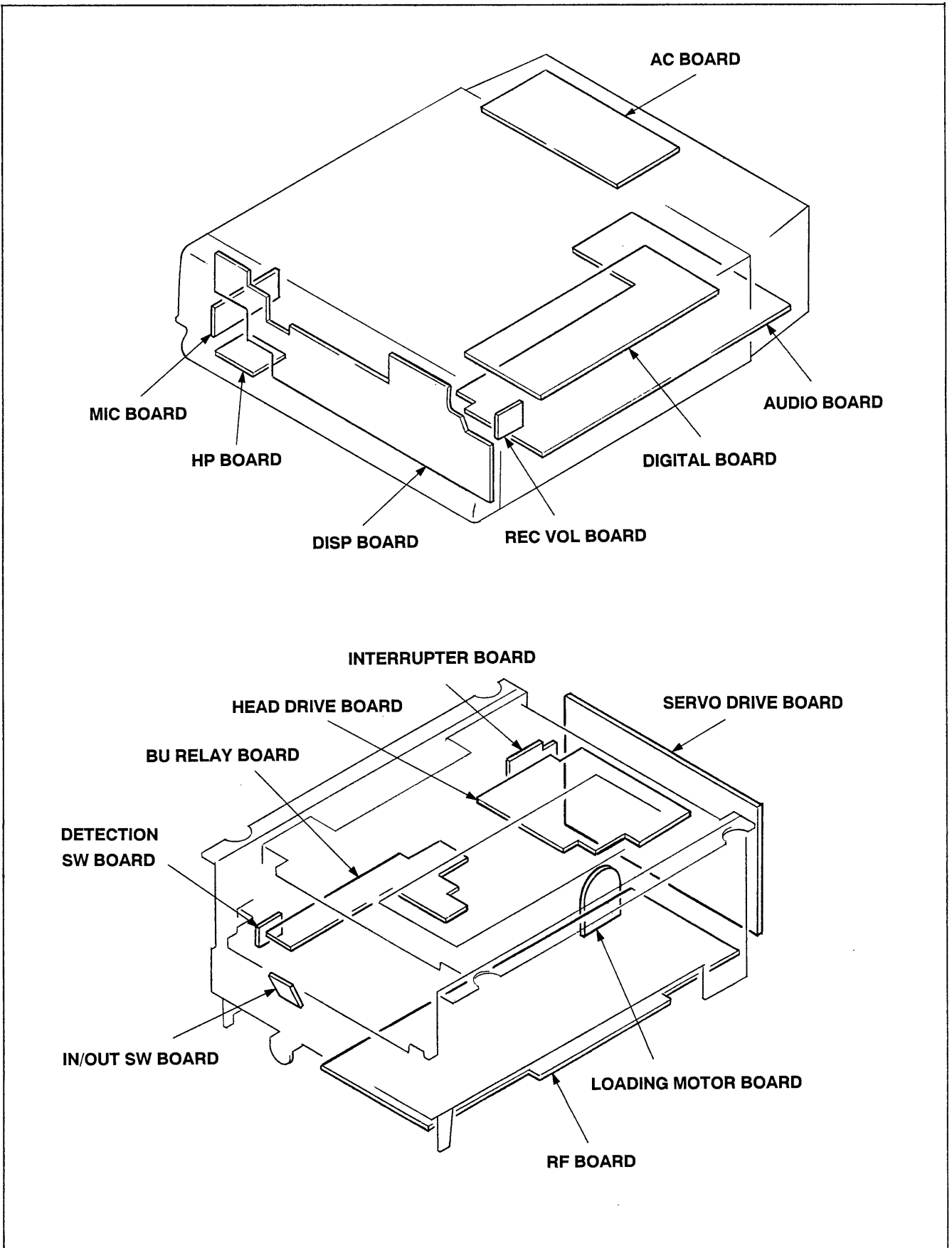

4-2. BLOCK DIAGRAM

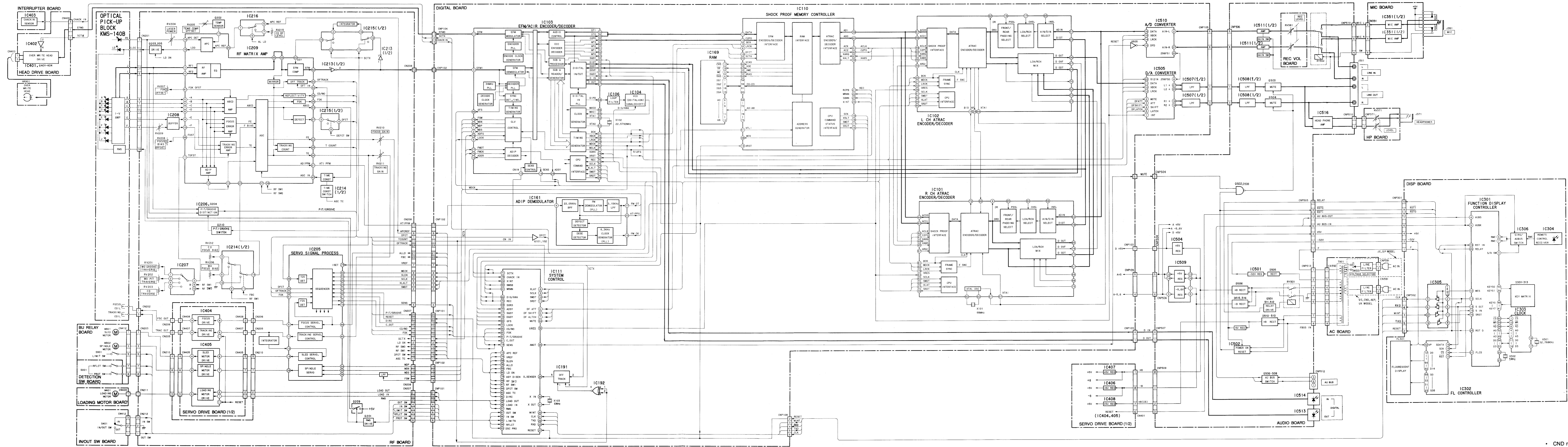

- CND model : Canadian model
- JE model : Tourist model
- SP model : Singapore model

4-3. PRINTED WIRING BOARD — RF SECTION —  
 • See page 38 for Circuit Boards Location and 81 for Semiconductor Lead Layouts.

SEMICONDUCTOR LOCATION

Ref. No.	Location
D202	D-21
D203	E-21
D204	E-16
D205	E-12
D401	E-2
D402	E-2
D403	F-2
D404	E-2
D405	F-2
D406	E-2
IC205	E-13
IC206	D-21
IC207	C-15
IC208	C-16
IC209	D-18
IC213	E-18
IC214	E-20
IC215	F-19
IC216	F-20
IC401	C-4
IC402	D-5
IC403	H-4
IC404	D-8
IC405	E-8
IC406	G-8
IC407	G-7
IC408	F-6
Q201	F-22
Q202	F-22
Q203	E-15
Q204	E-21
Q205	E-16
Q209	E-22
Q401	E-3
Q402	D-3
Q403	E-4
Q404	D-4

**Note:**  
 • ○ : Through hole.  
 • □ : Pattern from the side which enables seeing.  
 • □ : Pattern of the rear side.

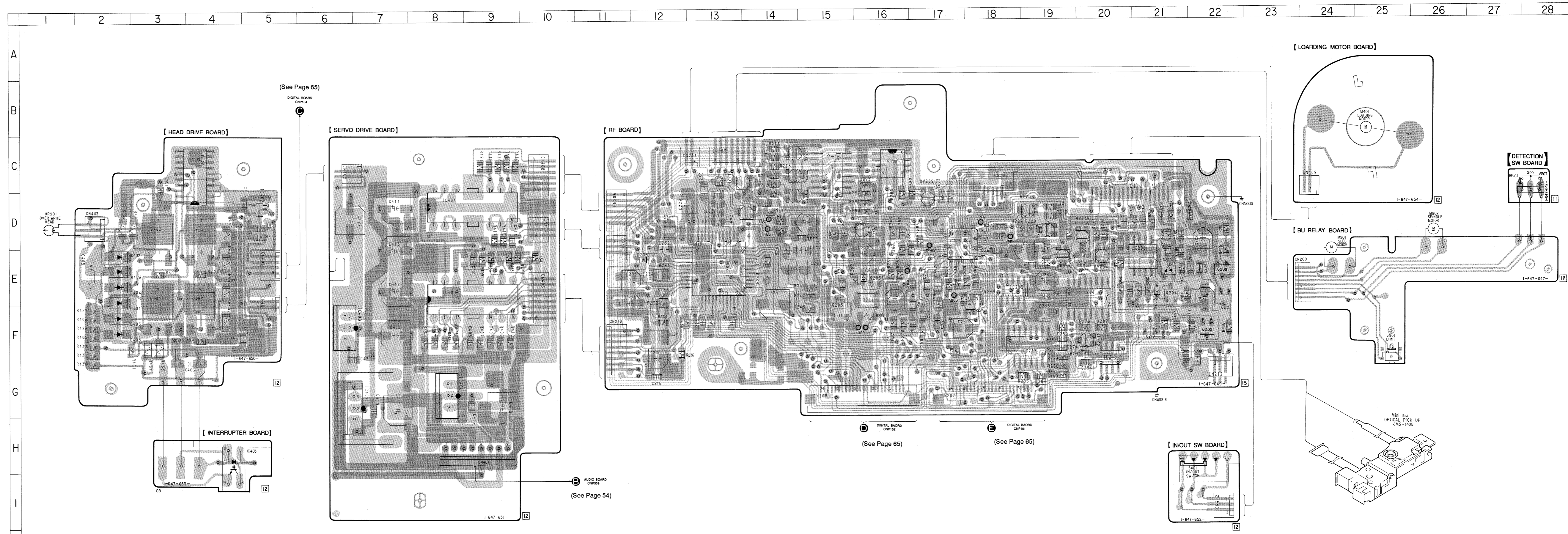



4-4. SCHEMATIC DIAGRAM — RF SECTION —  
• See page 77 to 80 for IC Block Diagrams.

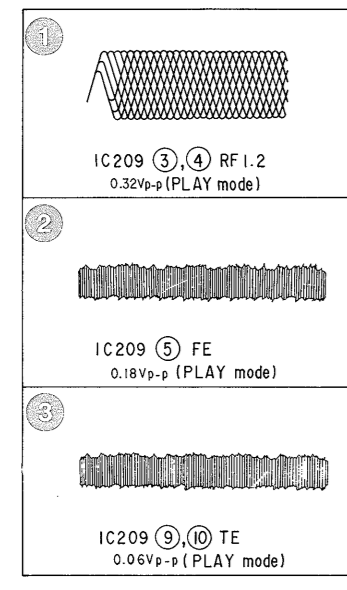
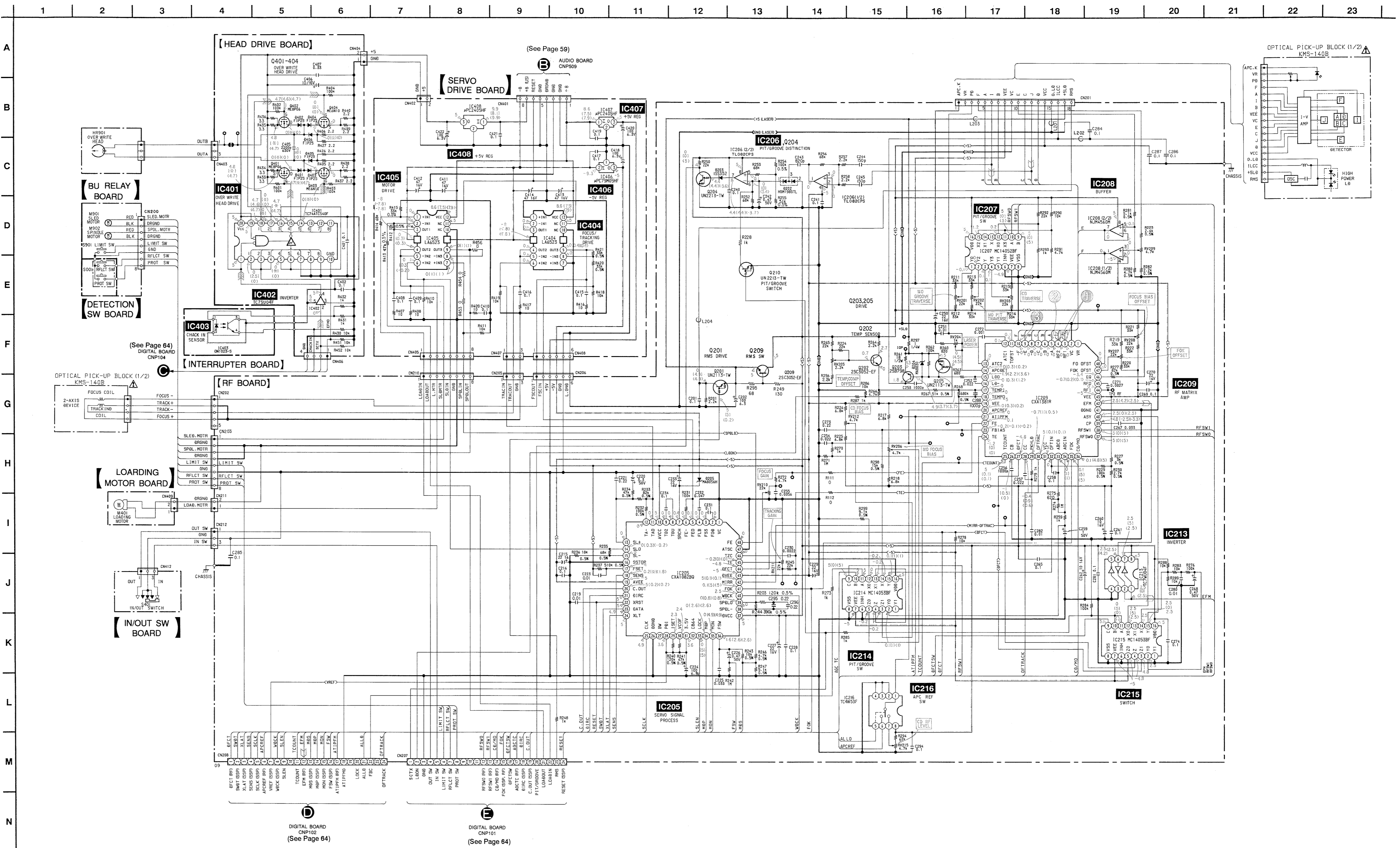

**Note:**

- All capacitors are in  $\mu\text{F}$  unless otherwise noted.  $\text{pF}$   $\mu\text{F}$  50WV or less are not indicated except for electrolytics and tantalums.
- All resistors are in  $\Omega$  and 1/4W or less unless otherwise specified.
- % indicates tolerance.
- ⊕ indicates B+ Line
- ⊖ indicates GND Line
- ⊕ indicates adjustment for repair.
- Voltages are DC between measurement points and ground.
- Voltages are taken with a VOM (input impedance 10M $\Omega$ ).
- Voltage variations may be noted due to normal production tolerances.
- no mark : STOP/PB/REC
- < : >PB
- ( ) : REC
- \* : impossible to measure the voltage at the marked points.
- Signal path.
- ⊕ : PB (ANALOG OUT) ⊕ : PB (DIGITAL OUT)
- ⊕ : REC (ANALOG IN) ⊕ : REC (DIGITAL IN)

**Note:**  
The components identified by mark  $\Delta$  or dotted line with mark  $\Delta$  are critical for safety. Replace only with part number specified.

**Note:**  
Les composants identifiés par une marque  $\Delta$  ou pointillés pour la sécurité. Ne les remplacer que par une pièce portant le numéro spécifié.

4-5. PRINTED WIRING BOARD — AUDIO SECTION —  
 • See page 38 for Circuit Boards Location and 81 for Semiconductor Lead Layouts.

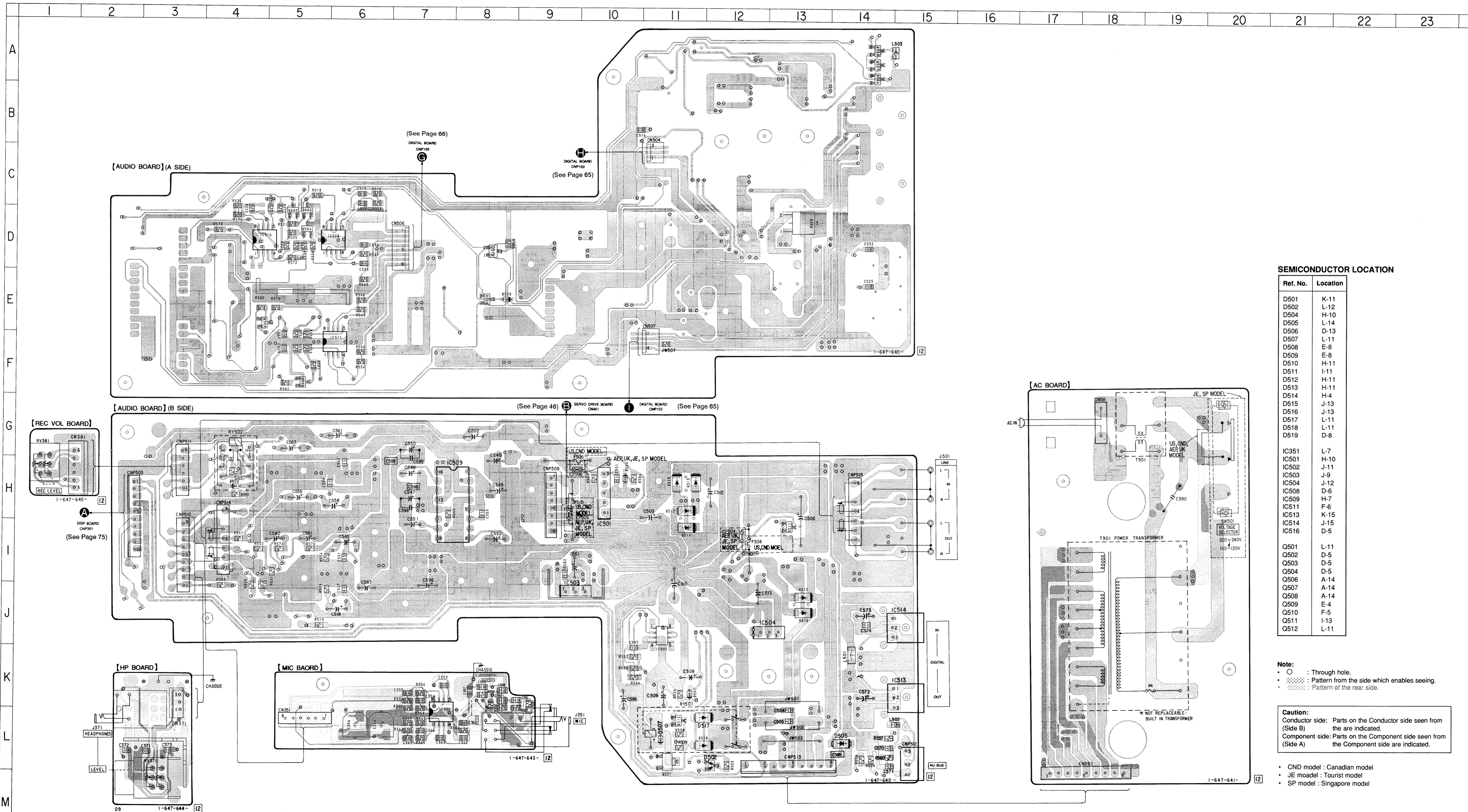

SEMICONDUCTOR LOCATION

Ref. No.	Location
D501	K-11
D502	L-12
D504	H-10
D505	L-14
D506	D-13
D507	L-11
D508	E-8
D509	E-8
D510	H-11
D511	I-11
D512	H-11
D513	H-11
D514	H-4
D515	J-13
D516	J-13
D517	L-11
D518	L-11
D519	D-8
IC351	L-7
IC501	H-10
IC502	J-11
IC503	J-9
IC504	J-12
IC508	D-6
IC509	H-7
IC511	F-6
IC513	K-15
IC514	J-15
IC516	D-5
Q501	L-11
Q502	D-5
Q503	D-5
Q504	D-5
Q506	A-14
Q507	A-14
Q508	A-14
Q509	E-4
Q510	F-5
Q511	I-13
Q512	L-11

Note:  
 • ○ : Through hole.  
 • ○ (with dot) : Pattern from the side which enables seeing.  
 • ○ (with horizontal lines) : Pattern of the rear side.

Caution:  
 Conductor side: Parts on the Conductor side seen from (Side B) are indicated.  
 Component side: Parts on the Component side seen from (Side A) are indicated.

- CND model : Canadian model
- JE model : Tourist model
- SP model : Singapore model

4-6. SCHEMATIC DIAGRAM — AUDIO SECTION —  
• See page 77 to 80 for IC Block Diagrams.

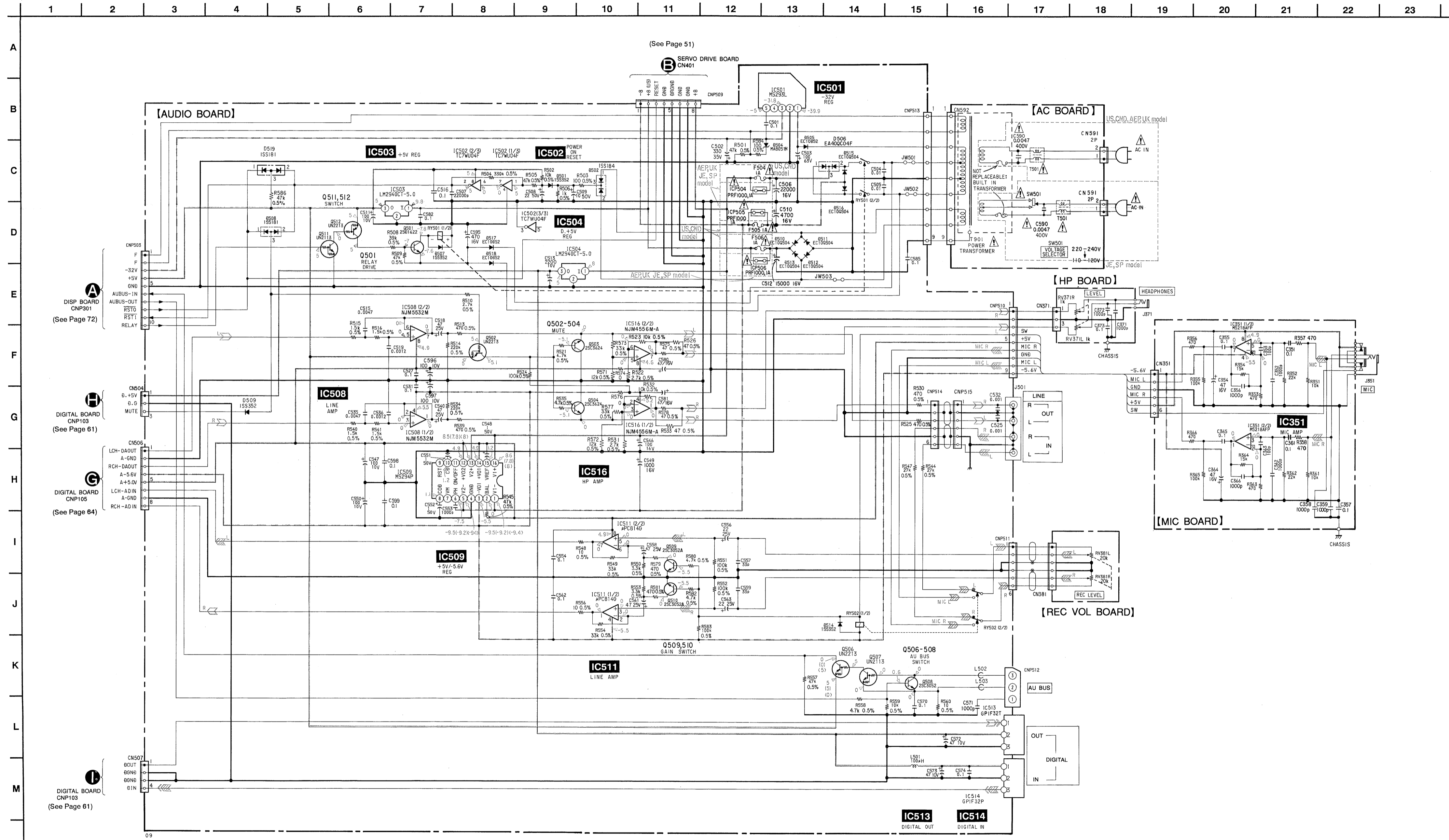

**Note:**

- All capacitors are in  $\mu\text{F}$  unless otherwise noted.  $\text{pF}$ :  $\mu\text{F}$  50WV or less are not indicated except for electrolytics and tantalums.
- All resistors are in  $\Omega$  and 1/4W or less unless otherwise specified.
- % : indicates tolerance.
- : B+ Line
- - - : B- Line
- : adjustment for repair.
- Voltages are DC between measurement points and ground.
- Voltages are taken with a VOM (input impedance 10M $\Omega$ ). Voltage variations may be noted due to normal production tolerances.
- no mark : STOP/PB/REC
- < : PB
- ( ) : REC
- ✕ : impossible to measure the voltage at the marked points.
- Signal path:
  - : PB (ANALOG OUT) — : PB (DIGITAL OUT)
  - : REC (ANALOG IN) — : REC (DIGITAL IN)

**Note:** The components identified by mark  $\Delta$  or dotted line with mark  $\Delta$  are critical for safety. Ne les remplacer que par une pièce portant le numéro spécifié.

**Note:** Les composants identifiés par une marque  $\Delta$  sont critiques pour la sécurité. Ne les remplacer que par une pièce portant le numéro spécifié.

- CND model : Canadian model
- JE model : Tourist model
- SP model : Singapore model

4-7. SCHEMATIC DIAGRAM — DIGITAL SECTION —  
 • See page 77 to 80 for IC Block Diagrams.

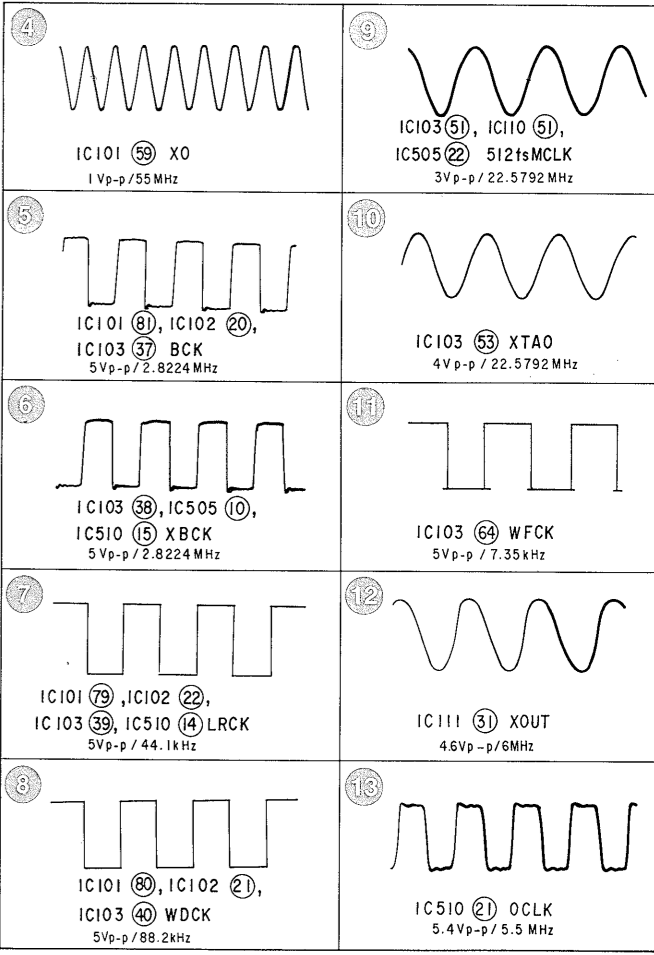
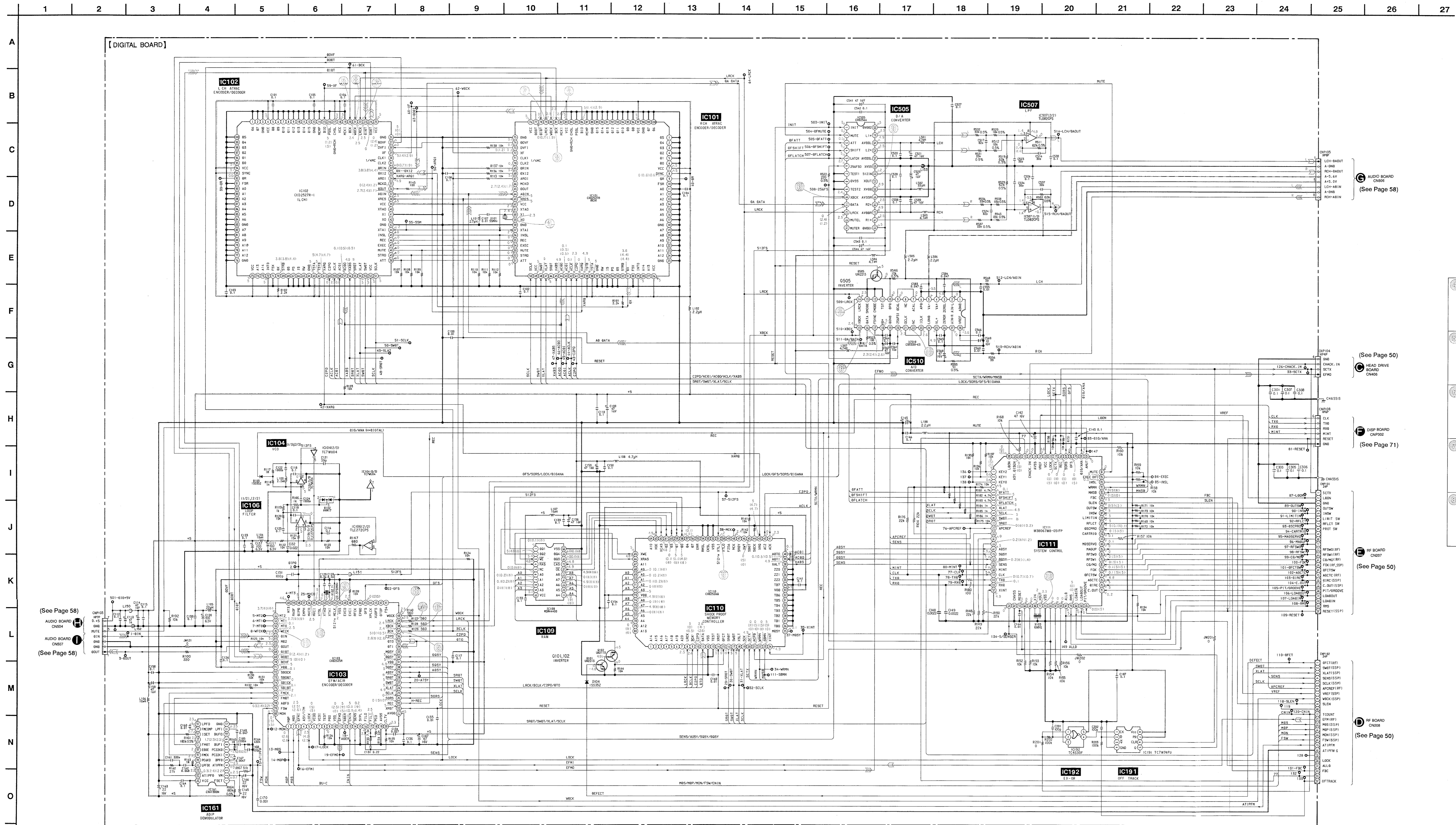

(See Page 58)

(See Page 50)

(See Page 71)

(See Page 50)

(See Page 50)

**Note:**

- All capacitors are in  $\mu\text{F}$  unless otherwise noted.  $\text{pF}$ ,  $\mu\text{H}$ , 50WV or less are not indicated except for electrolytics and tantalums.
- All resistors are in  $\Omega$  and 1/4W or less unless otherwise specified.
- % : indicates tolerance.
- B : B-Line
- : adjustment for repair.
- Voltage are DC between measurement points and ground.
- Voltagers are taken with a VOM (Input impedance 10M $\Omega$ ).
- Voltage variations may be noted due to normal production tolerances.
- no mark : STOP/PB/REC
- < : PB
- ( ) : REC
- \* : Impossible to measure the voltage at the marked points.
- Signal path.
- >>> : PB (ANALOG OUT) >>>> : PB (DIGITAL OUT)
- ||||| : REC (ANALOG IN) ||||| : REC (DIGITAL IN)

**Note:** The components identified by mark  $\Delta$  or dotted line with mark  $\Delta$  are critical for safety. Replace only with part number specified.

**Note:** Les composants identifiés par une marque  $\Delta$  sont critiques pour la sécurité. Ne les remplacer que par une pièce portant le numéro spécifique.

4-8. PRINTED WIRING BOARD — DIGITAL SECTION —  
 • See page 38 for Circuit Boards Location and 81 for Semiconductor Lead Layouts.

SEMICONDUCTOR LOCATION

Ref. No.	Location
D102	G-6
D103	H-6
D104	J-5
IC101	E-4
IC102	E-12
IC103	H-4
IC104	G-6
IC106	G-6
IC109	G-10
IC110	I-10
IC111	K-4
IC161	G-12
IC191	M-11
IC192	M-12
IC505	C-12
IC507	A-12
IC510	C-9
Q101	J-10
Q102	J-10
Q181	J-8
Q505	J-9

Note:  
 • ○ : Through hole.  
 • ◐ : Pattern from the side which enables seeing.

Caution:  
 Conductor side: Parts on the Conductor side seen from (Side B) are indicated.  
 Component side: Parts on the Component side seen from (Side A) are indicated.

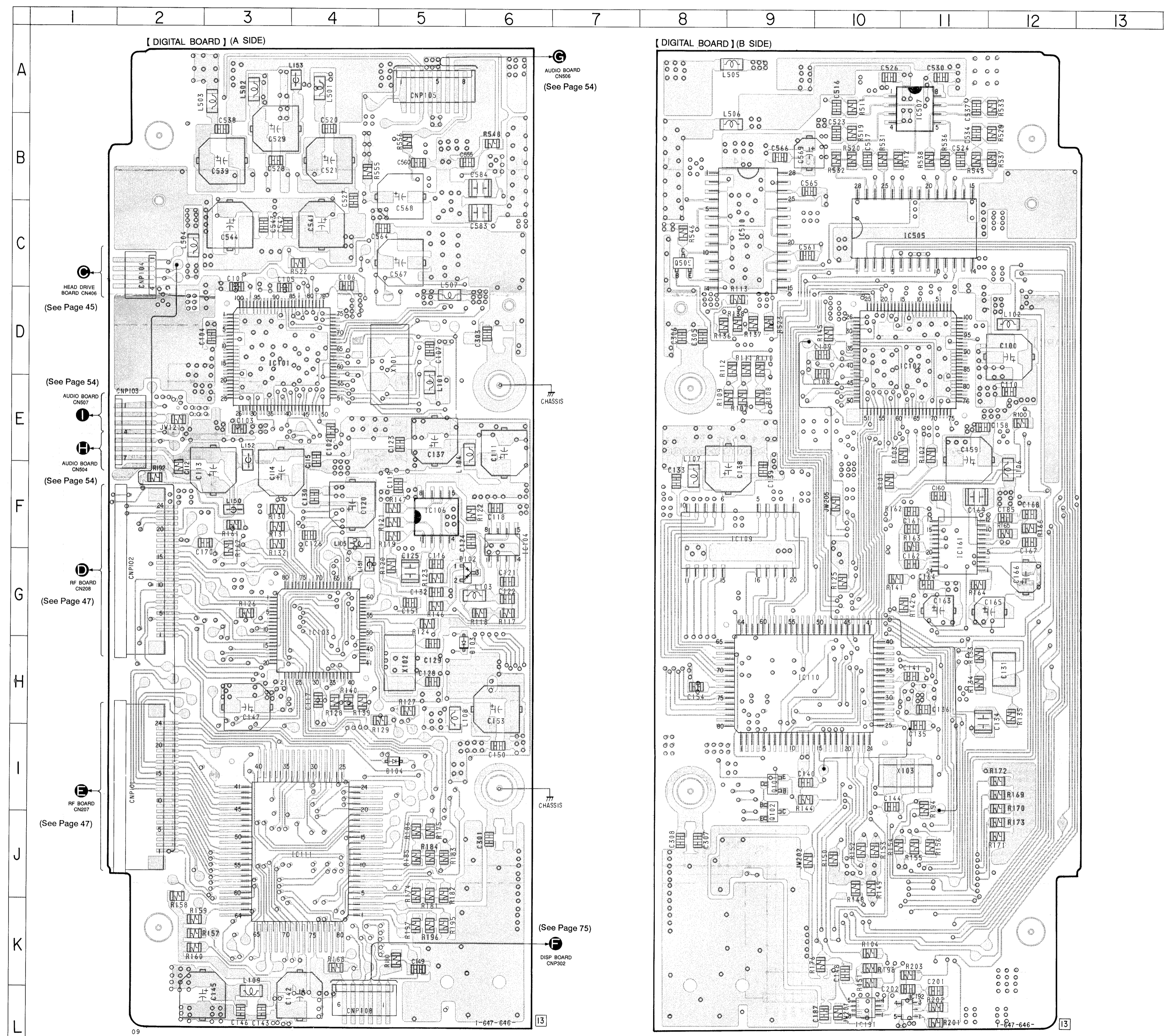

4-9. SCHEMATIC DIAGRAM — DISPLAY SECTION —  
• See page 77 to 80 for IC Block Diagrams.

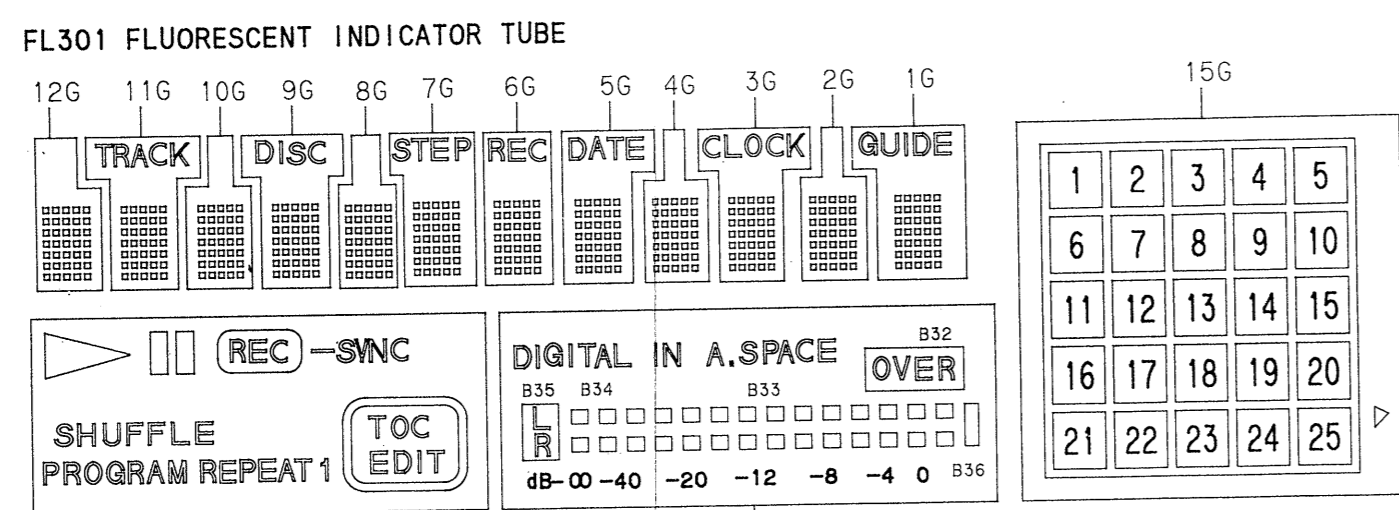
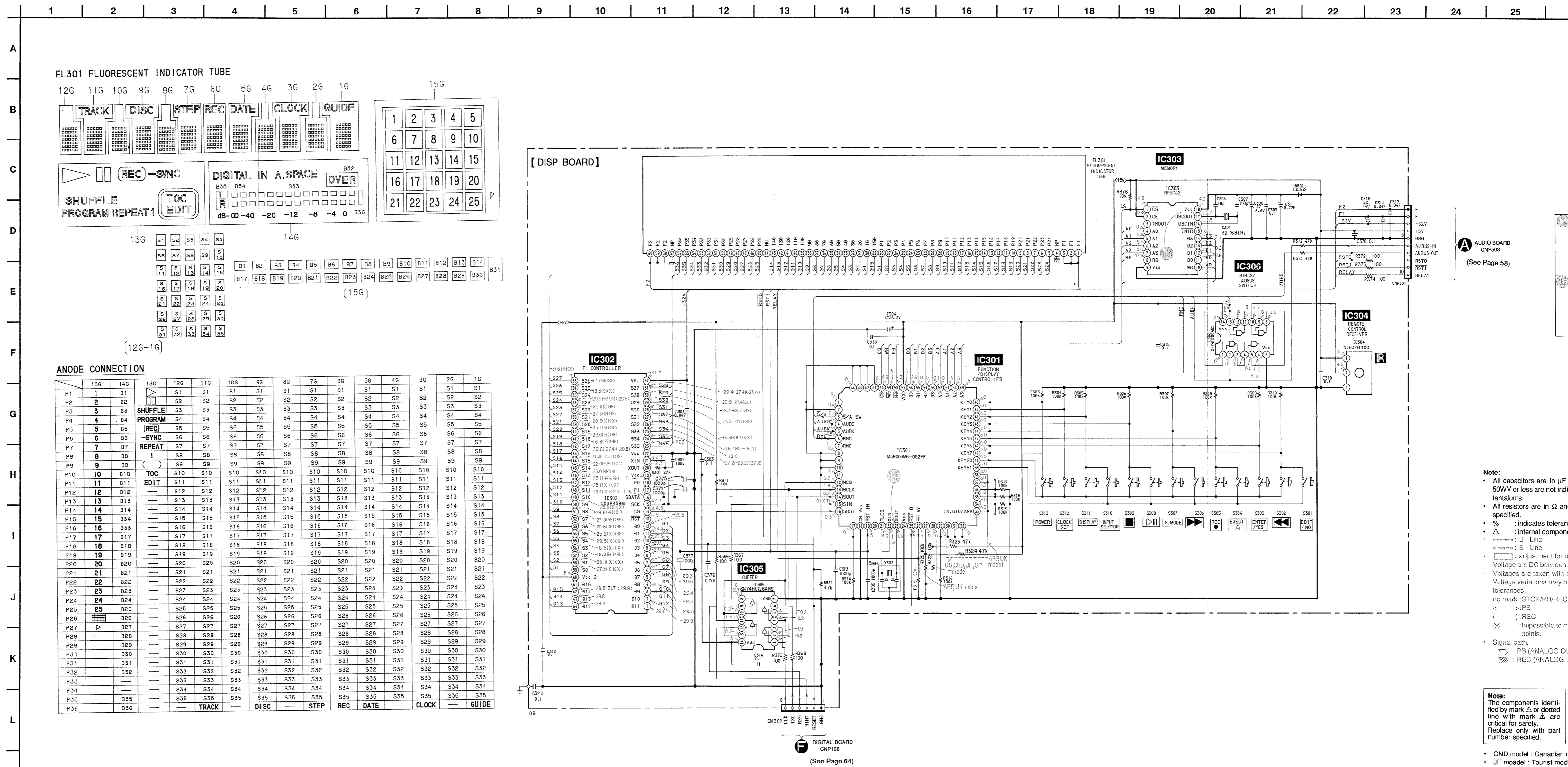

ANODE CONNECTION

	15G	14G	13G	12G	11G	10G	9G	8G	7G	6G	5G	4G	3G	2G	1G
P1	1	B1		S1	S1	S1	S1	S1	S1	S1	S1	S1	S1	S1	S1
P2	2	B2		S2	S2	S2	S2	S2	S2	S2	S2	S2	S2	S2	S2
P3	3	B3	SHUFFLE	S3	S3	S3	S3	S3	S3	S3	S3	S3	S3	S3	S3
P4	4	B4	PROGRAM	S4	S4	S4	S4	S4	S4	S4	S4	S4	S4	S4	S4
P5	5	B5	REC	S5	S5	S5	S5	S5	S5	S5	S5	S5	S5	S5	S5
P6	6	B6	-SYNC	S6	S6	S6	S6	S6	S6	S6	S6	S6	S6	S6	S6
P7	7	B7	REPEAT	S7	S7	S7	S7	S7	S7	S7	S7	S7	S7	S7	S7
P8	8	B8	1	S8	S8	S8	S8	S8	S8	S8	S8	S8	S8	S8	S8
P9	9	B9	TOC	S9	S9	S9	S9	S9	S9	S9	S9	S9	S9	S9	S9
P10	10	B10	EDIT	S10	S10	S10	S10	S10	S10	S10	S10	S10	S10	S10	S10
P11	11	B11		S11	S11	S11	S11	S11	S11	S11	S11	S11	S11	S11	S11
P12	12	B12		S12	S12	S12	S12	S12	S12	S12	S12	S12	S12	S12	S12
P13	13	B13		S13	S13	S13	S13	S13	S13	S13	S13	S13	S13	S13	S13
P14	14	B14		S14	S14	S14	S14	S14	S14	S14	S14	S14	S14	S14	S14
P15	15	B15		S15	S15	S15	S15	S15	S15	S15	S15	S15	S15	S15	S15
P16	16	B16		S16	S16	S16	S16	S16	S16	S16	S16	S16	S16	S16	S16
P17	17	B17		S17	S17	S17	S17	S17	S17	S17	S17	S17	S17	S17	S17
P18	18	B18		S18	S18	S18	S18	S18	S18	S18	S18	S18	S18	S18	S18
P19	19	B19		S19	S19	S19	S19	S19	S19	S19	S19	S19	S19	S19	S19
P20	20	B20		S20	S20	S20	S20	S20	S20	S20	S20	S20	S20	S20	S20
P21	21	B21		S21	S21	S21	S21	S21	S21	S21	S21	S21	S21	S21	S21
P22	22	B22		S22	S22	S22	S22	S22	S22	S22	S22	S22	S22	S22	S22
P23	23	B23		S23	S23	S23	S23	S23	S23	S23	S23	S23	S23	S23	S23
P24	24	B24		S24	S24	S24	S24	S24	S24	S24	S24	S24	S24	S24	S24
P25	25	B25		S25	S25	S25	S25	S25	S25	S25	S25	S25	S25	S25	S25
P26		B26		S26	S26	S26	S26	S26	S26	S26	S26	S26	S26	S26	S26
P27		B27		S27	S27	S27	S27	S27	S27	S27	S27	S27	S27	S27	S27
P28		B28		S28	S28	S28	S28	S28	S28	S28	S28	S28	S28	S28	S28
P29		B29		S29	S29	S29	S29	S29	S29	S29	S29	S29	S29	S29	S29
P30		B30		S30	S30	S30	S30	S30	S30	S30	S30	S30	S30	S30	S30
P31		B31		S31	S31	S31	S31	S31	S31	S31	S31	S31	S31	S31	S31
P32		B32		S32	S32	S32	S32	S32	S32	S32	S32	S32	S32	S32	S32
P33		B33		S33	S33	S33	S33	S33	S33	S33	S33	S33	S33	S33	S33
P34		B34		S34	S34	S34	S34	S34	S34	S34	S34	S34	S34	S34	S34
P35		B35		S35	S35	S35	S35	S35	S35	S35	S35	S35	S35	S35	S35
P36		B36		TRACK	DISC	STEP	REC	DATE	CLOCK	GUIDE					

AUDIO BOARD CNP503 (See Page 58)

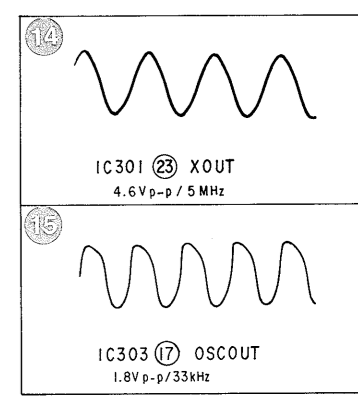

**Note:**

- All capacitors are in  $\mu F$  unless otherwise noted. pF= $\mu F$  50WV or less are not indicated except for electrolytics and tantalums.
- All resistors are in  $\Omega$  and 1/4W or less unless otherwise specified.
- % : indicates tolerance.
- $\Delta$  : internal component.
- $\square$  : adjustment for repair.
- $\square$  : PB (ANALOG OUT)  $\square$  : PB (DIGITAL OUT)
- $\square$  : REC (ANALOG IN)  $\square$  : REC (DIGITAL IN)
- no mark : STOP/PB/REC
- < : >PB
- ( ) : REC
- $\times$  : impossible to measure the voltage at the marked points.
- Signal path.
- SP : JE model ; Tourist model
- SP model : Singapore model

**Note:**

The components identified by mark  $\Delta$  or dotted line with mark  $\Delta$  are critical for safety. Replace only with part number specified.

**Note:**

Les composants identifiés par une marque  $\Delta$  sont critiques pour la sécurité. Ne les remplacer que par une pièce portant le numéro spécifié.

4-10. PRINTED WIRING BOARD — DISPLAY SECTION —  
 • See page 38 for Circuit Boards Location and 81 for Semiconductor Lead Layouts.

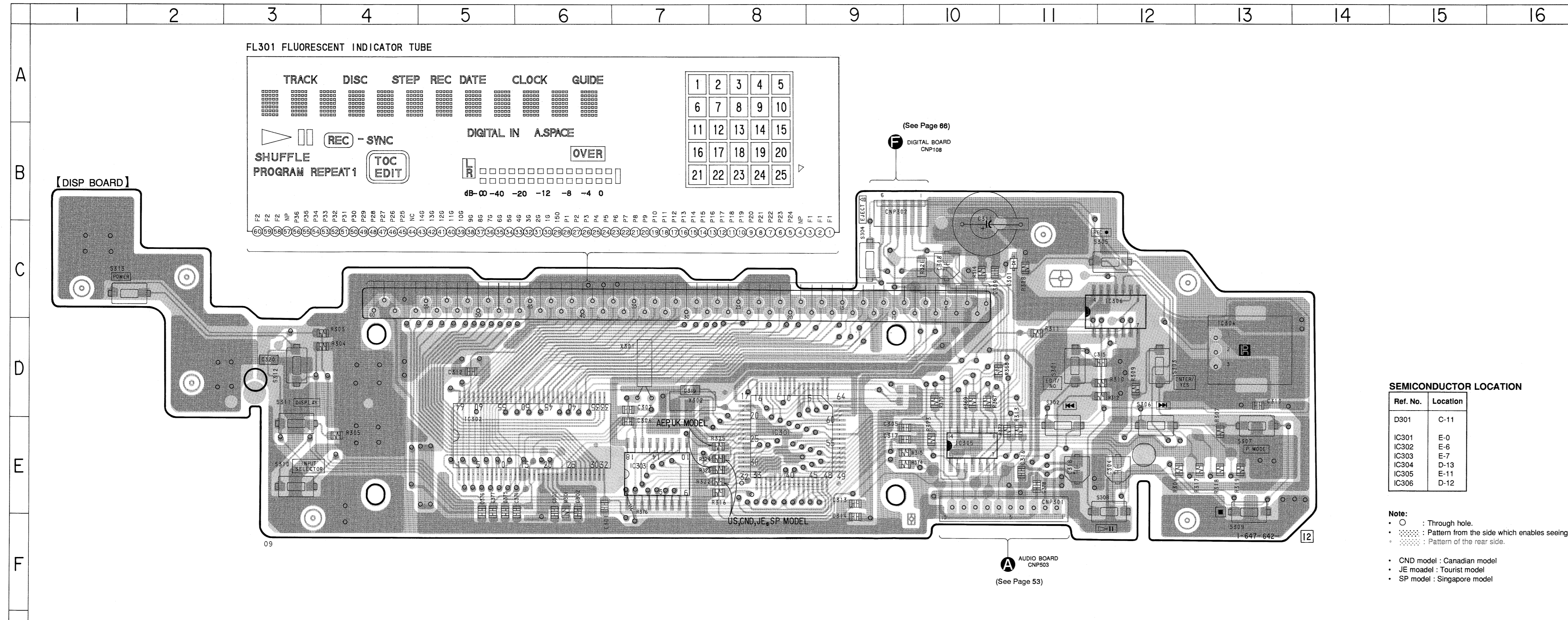

**SEMICONDUCTOR LOCATION**

Ref. No.	Location
D301	C-11
IC301	E-0
IC302	E-6
IC303	E-7
IC304	D-13
IC305	E-11
IC306	D-12

**Note:**  
 • ○ : Through hole.  
 • □ : Pattern from the side which enables seeing.  
 • ◐ : Pattern of the rear side.

- CND model : Canadian model
- JE model : Tourist model
- SP model : Singapore model

4-11. IC BLOCK DIAGRAMS

IC101 CXD2527R

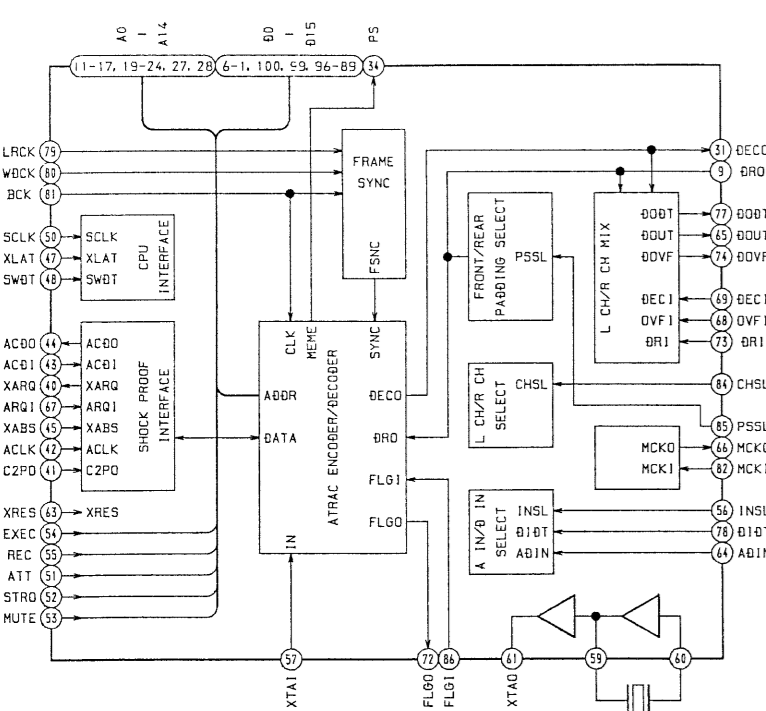

IC109 M5U44400

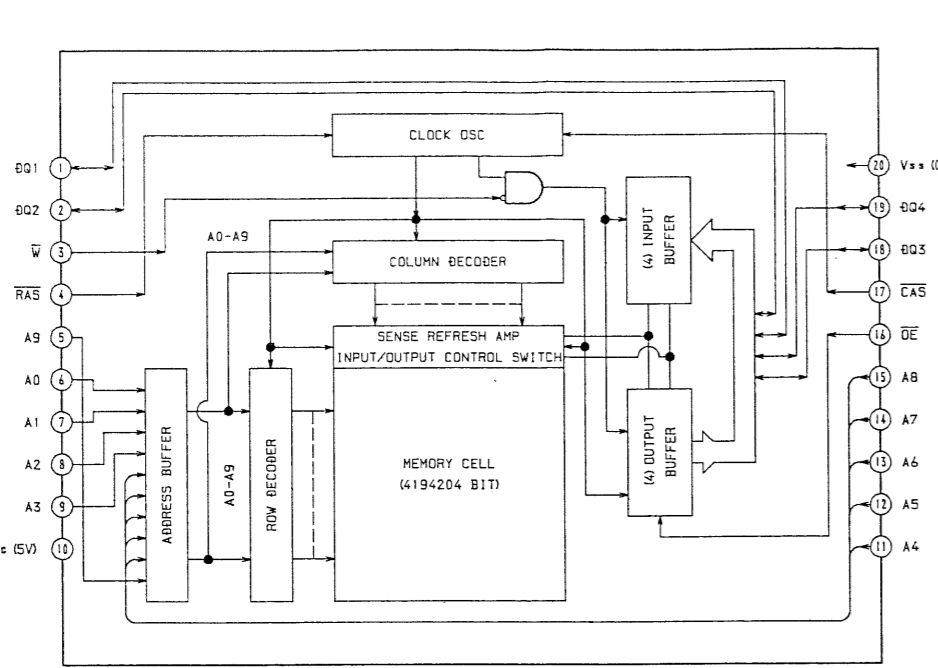

IC102 CXD2527R-1

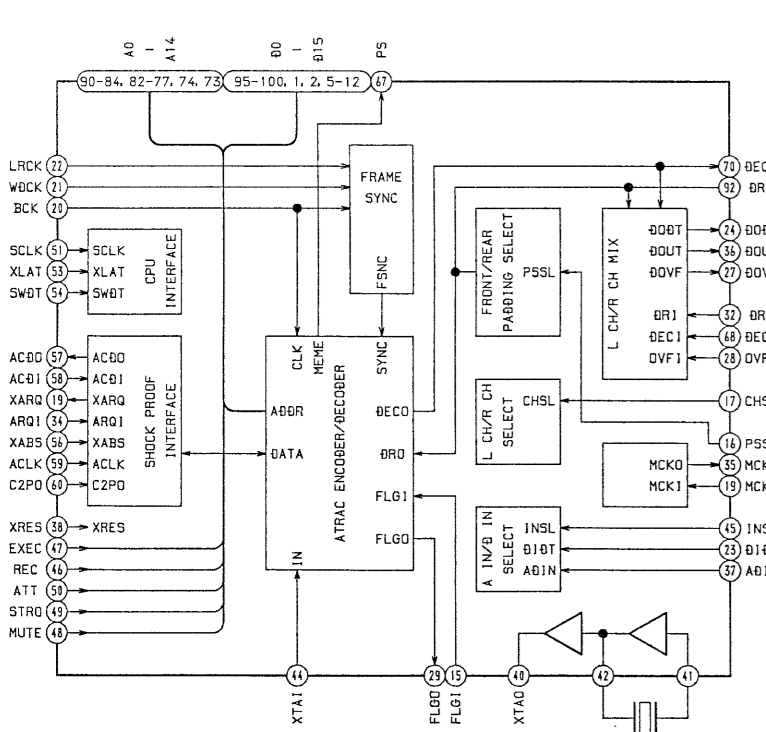

IC161 CXA1380N

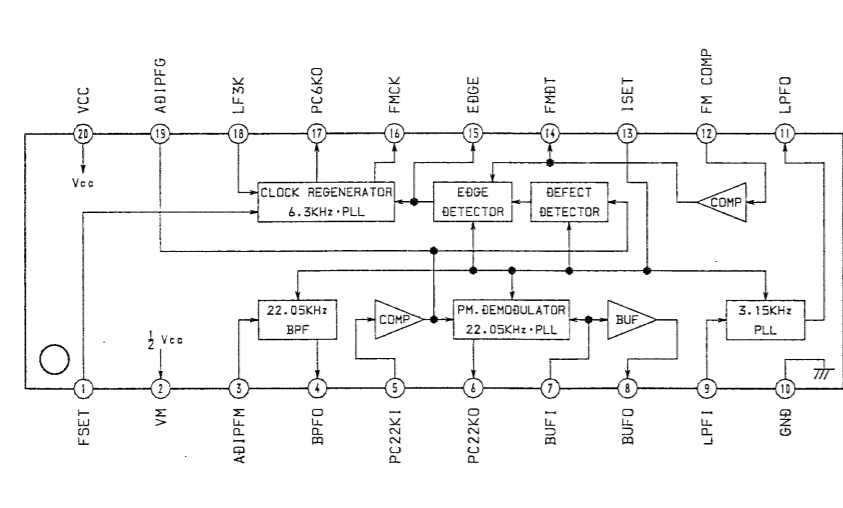

IC205 CXA1082BQ

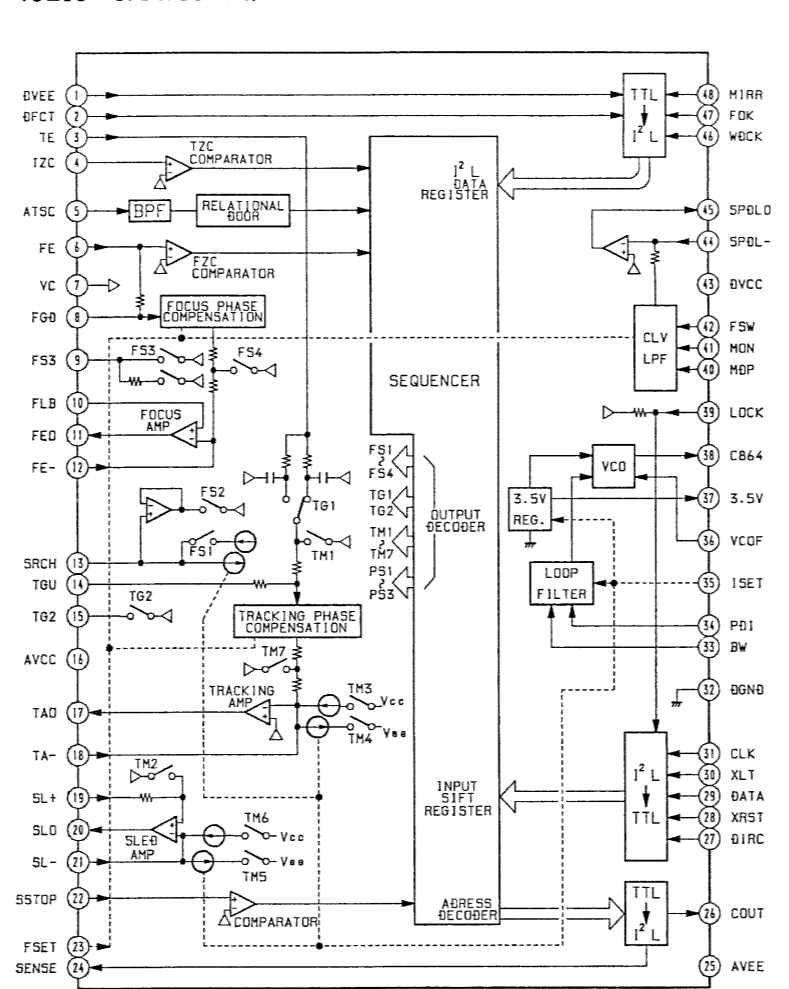

IC207 MC14052BF

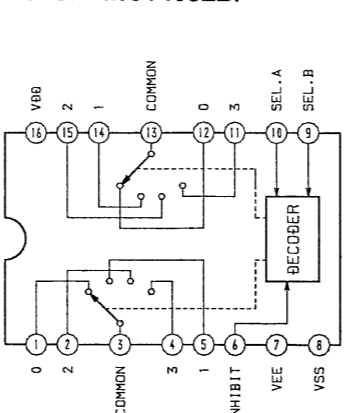

IC209 CXA1381R

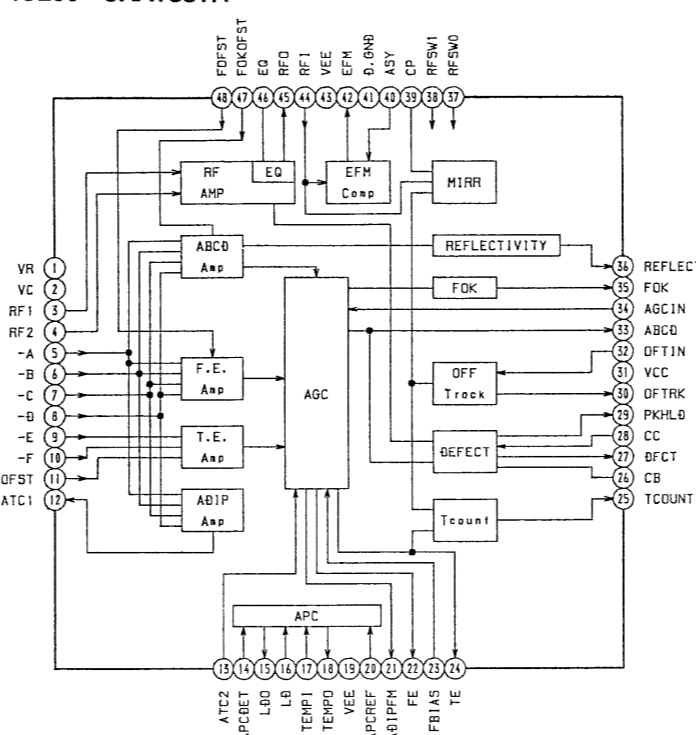

IC214, 215 MC14053BF

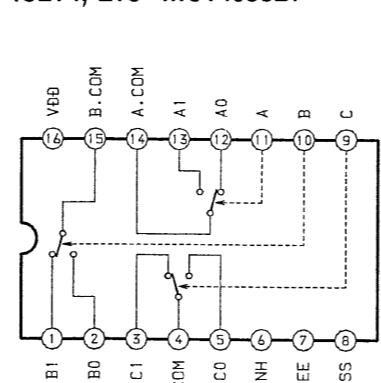

IC216 TC4W53F

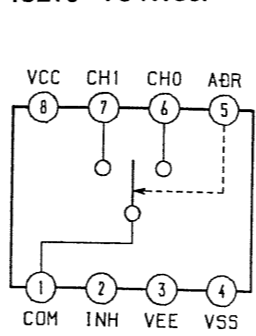

IC303 RF5C62

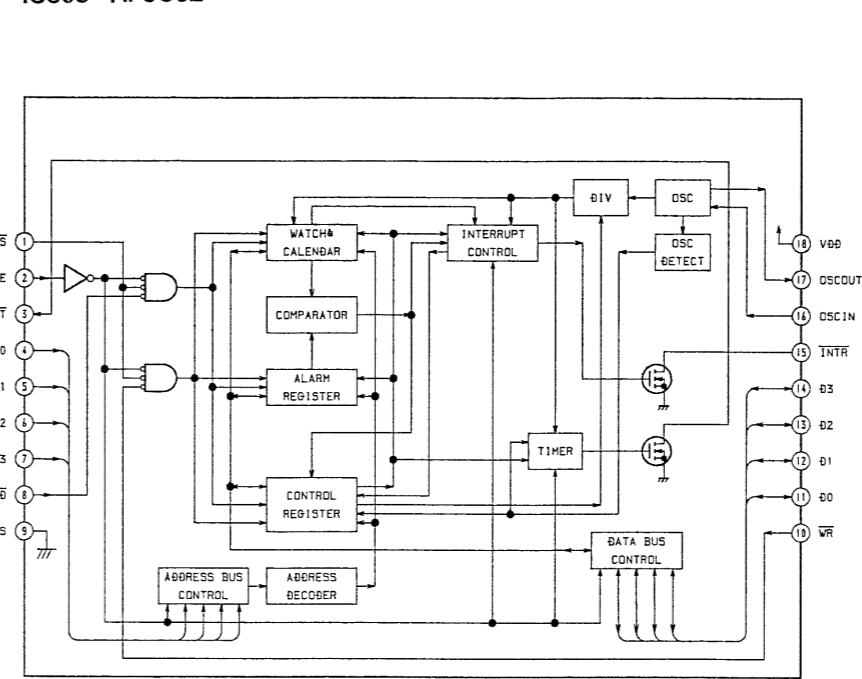

IC401 TC74ATC540F

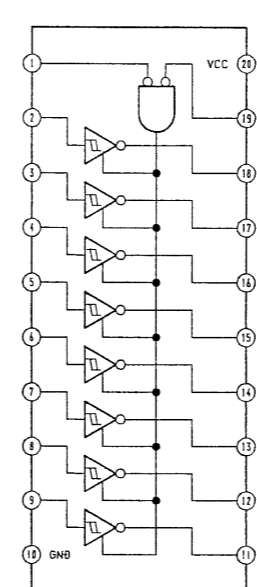

IC404, 405 LA6523

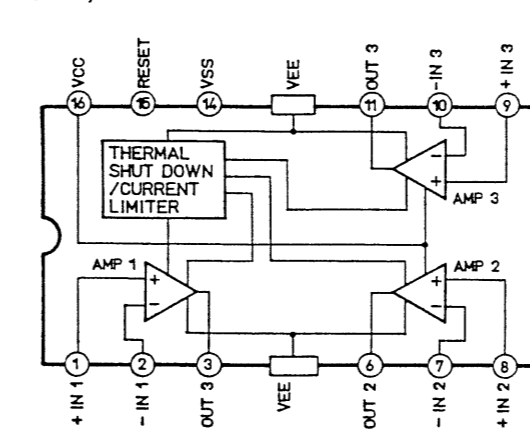

IC501 M5293L

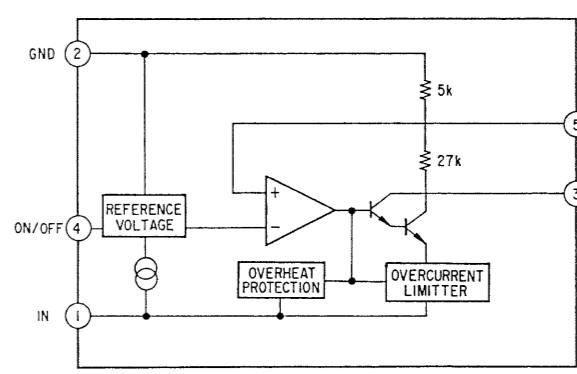

IC505 CXD2564M

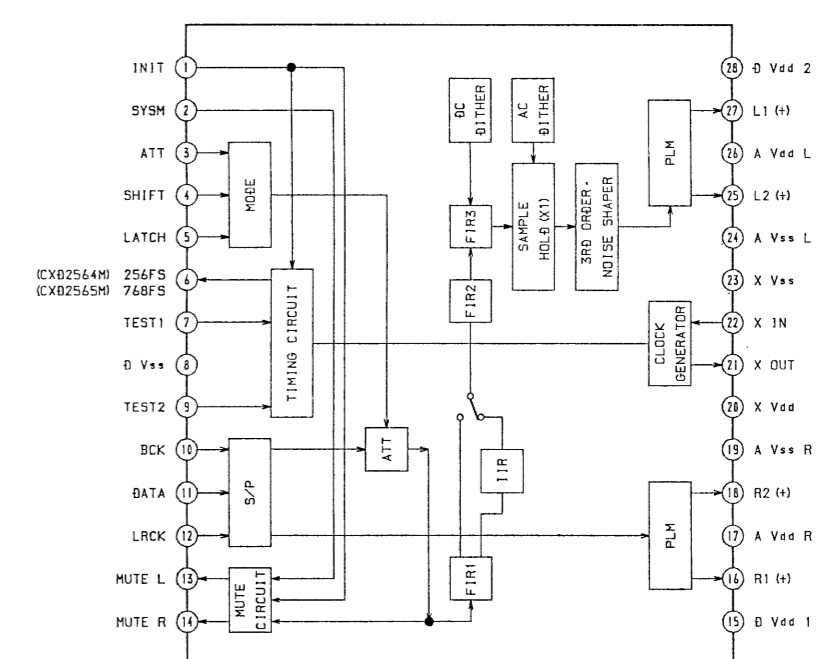

IC509 M5294P

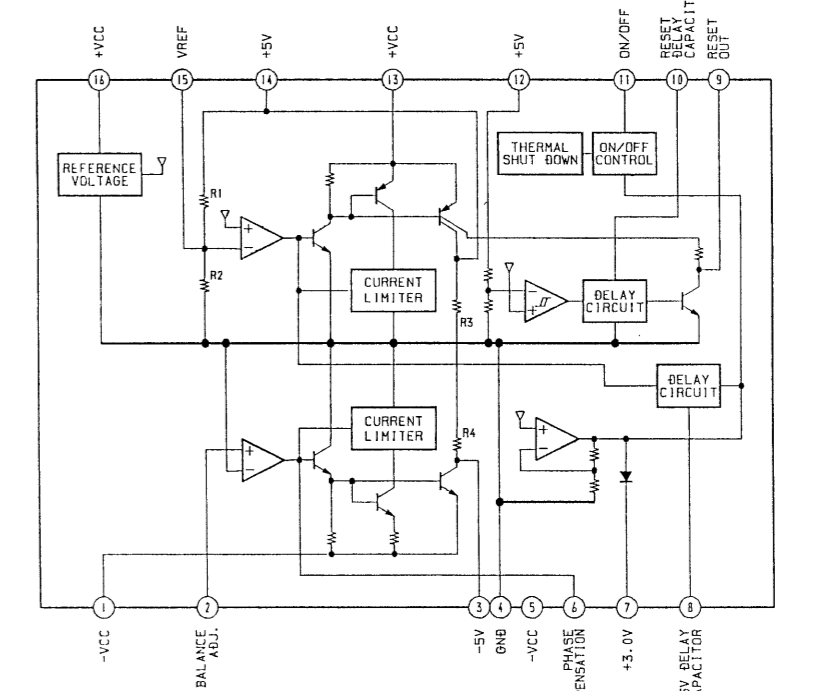

IC510 CS5339-KS

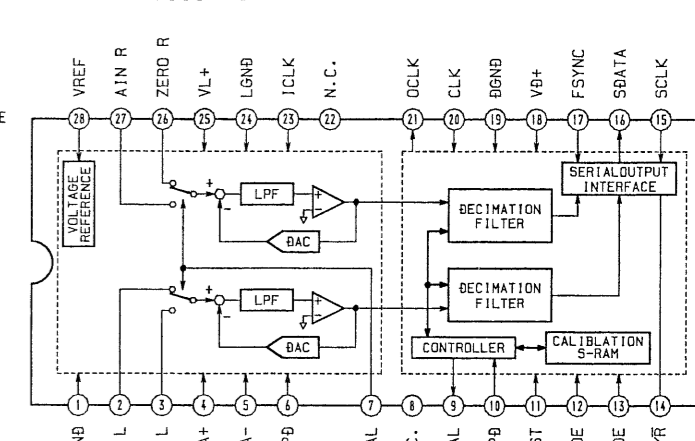



## 4-12. SEMICONDUCTOR LEAD LAYOUTS

CXA1082BQ  
CXA1381R

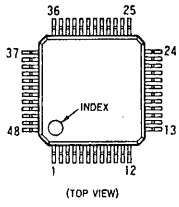

CXD2564M

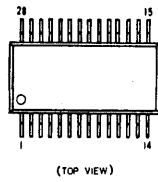

M38067M8-051FP

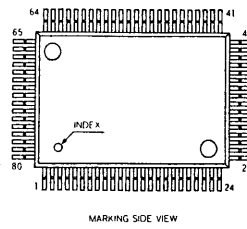

TC4S30F  
TC7WU04F

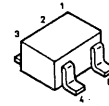

CXD8459M



M5293L

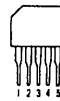

uPC2405HF  
uPC79M05HF

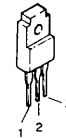

CXA1380N

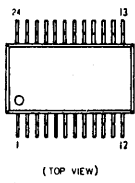

GP1F32R  
GP1F32T

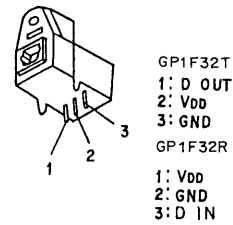

M5M44400ATP-8L

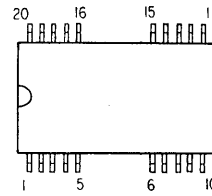

2SB798-DL  
2SD1622-S

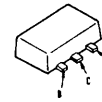

CXD2527R

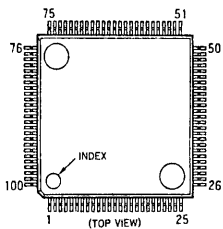

NJM32H400

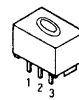

ME6N10  
ME8P06

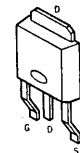

LA6523



CXD2527R-1

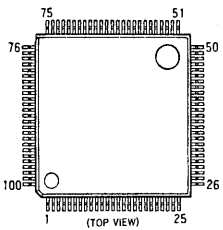

LM2940CT-5.0



ON1023-S

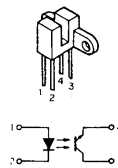

1SS352  
DTZ5.6B

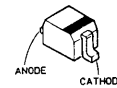

CXD2525R

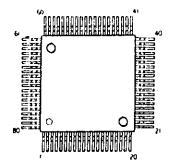

M38003M6-050FP

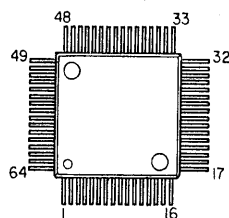

RF5C62

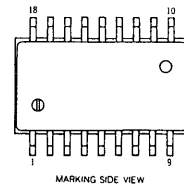

EC10DS2  
EC10QS-04  
F1P2STP

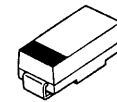

CXD2526Q

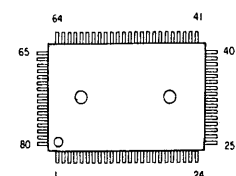

MA8030  
MA8051-H

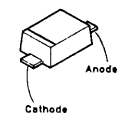

## SECTION 5 EXPLODED VIEWS

**NOTE:**

- -XX, -X mean standardized parts, so they may have some difference from the original one.
- Color Indication of Appearance Parts  
Example:  
KNOB, BALANCE (WHITE) . . . (RED)  
                  ↑                                  ↑  
          Parts color                  Cabinet's color
- JE : Tourist model
- SP : Singapore model

- Items marked " \* " are not stocked since they are seldom required for routine service. Some delay should be anticipated when ordering these items.
- The mechanical parts with no reference number in the exploded views are not supplied.
- Hardware (# mark) list is given in the last of this parts list.

The components identified by mark  $\Delta$  or dotted line with mark  $\Delta$  are critical for safety. Replace only with part number specified.

Les composants identifiés par une marque  $\Delta$  sont critiques pour la sécurité. Ne les remplacer que par une pièce portant le numéro spécifié.

### 5-1. CASE AND FRONT PANEL SECTION

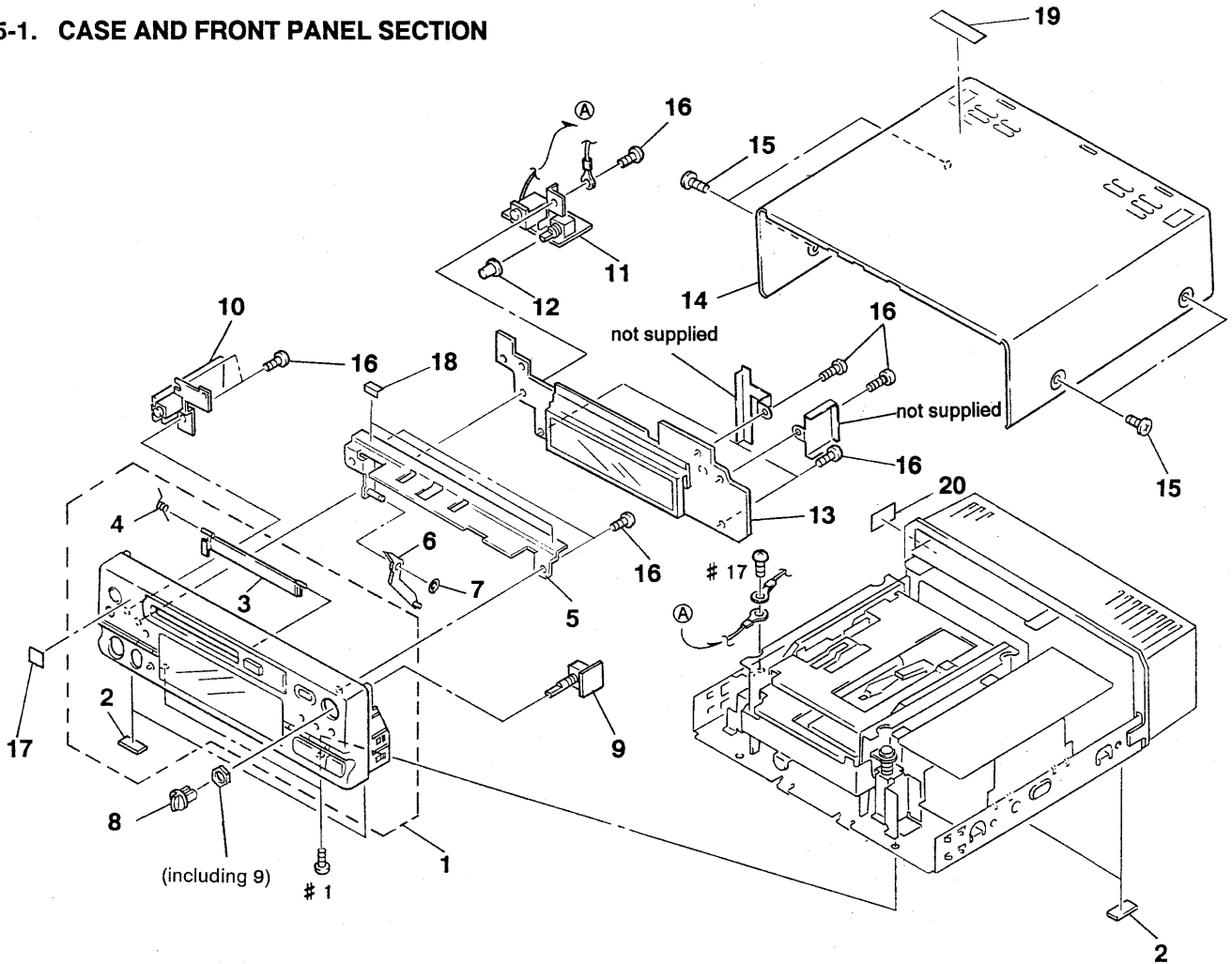

Ref. No.	Part No.	Description	Remark	Ref. No.	Part No.	Description	Remark
1	X-4943-199-1	PANEL ASSY, FRONT (AEP, UK, JE, SP)		12	4-956-137-01	KNOB (HP VOL) (AEP, UK, JE, SP)	
1	X-4943-692-2	PANEL ASSY, FRONT (US, Canadian)		12	4-956-137-21	KNOB (HP VOL) (US, Canadian)	
2	4-930-336-11	FOOT (FELT)		* 13	A-4649-693-A	DISP BOARD, COMPLETE (US, Canadian, JE, SP)	
3	4-956-123-01	LID (AEP, UK, JE, SP)		* 13	A-4649-697-A	DISP BOARD, COMPLETE (AEP, UK)	
3	4-956-123-21	LID (US, Canadian)		* 14	4-956-878-01	CASE (AEP, UK, JE, SP)	
4	4-956-130-01	SPRING (LID), TORSION		14	4-956-878-11	CASE (US, Canadian)	
* 5	X-4943-202-1	REINFORCEMENT ASSY		15	3-363-099-01	SCREW (CASE 3 TP2)	
6	4-956-132-01	LEVER (LID)		16	4-951-620-01	SCREW (2.6X8), +BVTP	
7	3-558-708-01	WASHER, STOPPER		* 17	3-703-713-41	STICKER, SONY SYMBOL (10) (US, Canadian, AEP, UK)	
8	3-382-510-01	KNOB (REC)		18	3-831-441-01	CUSHION (B)	
* 9	1-647-645-11	REC VOL BOARD		* 19	4-950-766-01	LABEL, FCC DIGITAL DEVICE (US)	
* 10	A-4649-442-A	MIC BOARD, COMPLETE		* 20	4-951-548-01	LABEL, CLASS 1 (AEP, UK, JE, SP)	
* 11	1-647-644-11	HP BOARD					

## 5-2. CHASSIS SECTION

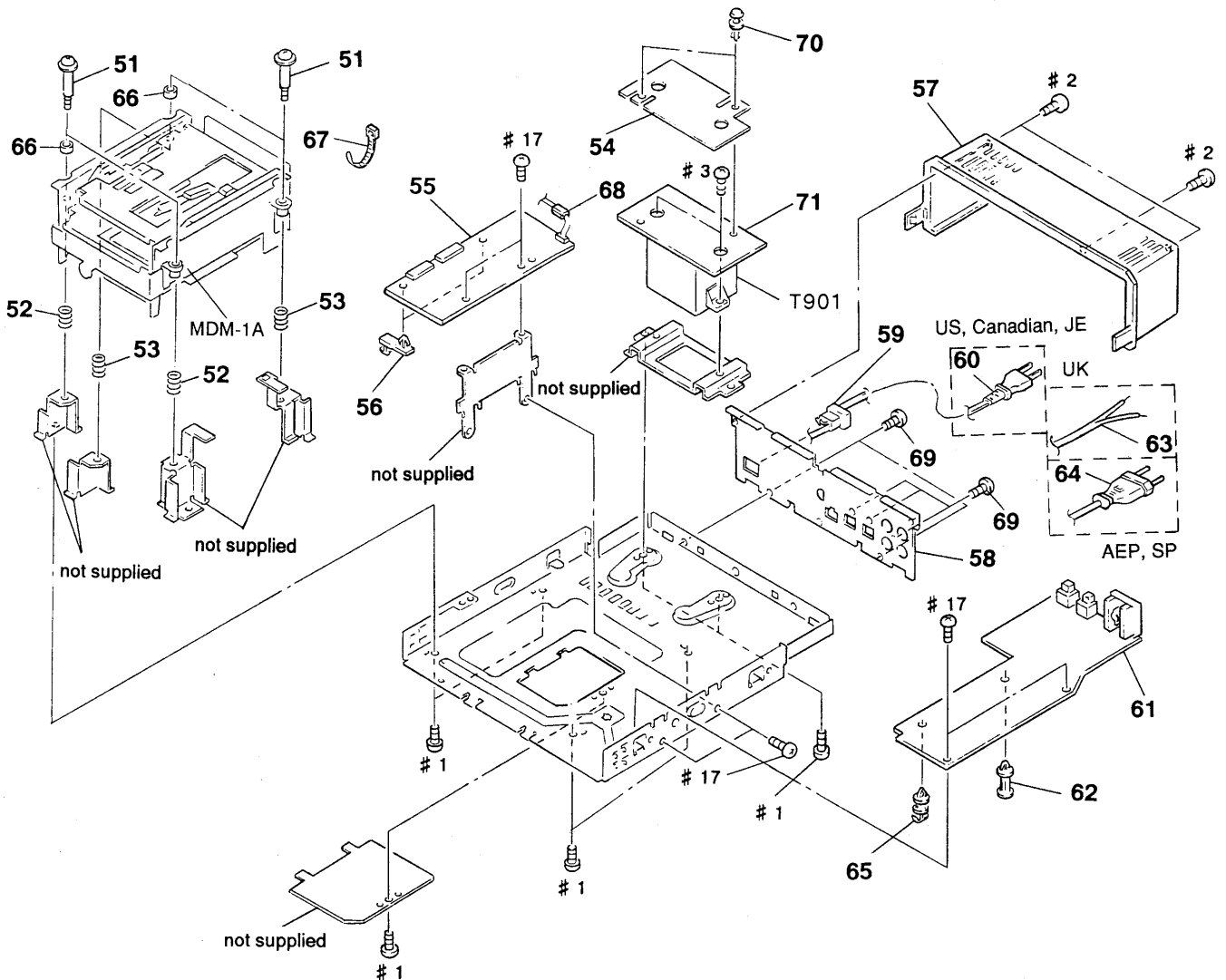

The components identified by mark ▲ or dotted line with mark △ are critical for safety. Replace only with part number specified.

Les composants identifiés par une marque ▲ sont critiques pour la sécurité. Ne les remplacer que par une pièce portant le numéro spécifié.

Ref. No.	Part No.	Description	Remark	Ref. No.	Part No.	Description	Remark
51	4-955-097-11	SCREW(C), TRANSPORT		* 61	A-4649-694-A	AUDIO BOARD, COMPLETE (AEP, UK, JE, SP)	
* 52	4-958-087-01	SPRING (FRONT), COMPRESSION (SILVER)		* 62	3-669-610-00	SPACER	
* 53	4-958-088-01	SPRING (REAR), COMPRESSION (BLACK)		▲63	1-696-586-21	CORD, POWER (UK)	
* 54	4-958-109-01	COVER (POWER)		▲64	1-751-275-11	CORD, POWER (AEP, SP)	
* 55	A-4649-446-A	DIGITAL BOARD, COMPLETE		* 65	4-958-674-01	SPACER, MINITURE CARD	
* 56	3-696-448-01	HINGE, SS		66	4-958-120-01	BUSHING (DAMPER)	
* 57	4-956-138-01	PANEL, BACK		67	3-655-653-01	BAND (TAITON), BINDING	
* 58	4-956-136-11	PLATE, JACK (JE, SP)		68	1-500-051-11	BEAD, FERRITE (WITH CASE)	
* 58	4-956-136-21	PLATE, JACK (US, Canadian, AEP, UK)		69	3-703-685-21	SCREW (+BV 3X8)	
* 59	3-703-244-00	BUSHING (2104), CORD (AEP, UK, SP)		70	4-812-134-00	RIVET NYLON, 3.5	
* 59	3-703-571-00	BUSHING (S) (4516), CORD (JE)		* 71	1-647-641-11	AC BOARD	
* 59	3-703-571-11	BUSHING (S) (4516), CORD (US, Canadian)		▲T901	1-423-398-11	TRANSFORMER, POWER (US, Canadian)	
▲60	1-558-945-21	CORD, POWER (POLAR. SPT-1) (US, Canadian)		▲T901	1-423-399-11	TRANSFORMER, POWER (AEP)	
▲60	1-696-027-11	CORD, POWER (JE)		▲T901	1-423-400-11	TRANSFORMER, POWER (UK)	
* 61	A-4649-690-A	AUDIO BOARD, COMPLETE (US, Canadian)		▲T901	1-423-401-11	TRANSFORMER, POWER (JE, SP)	

5-3. MECHANISM DECK SECTION-1  
(MDM-1A)

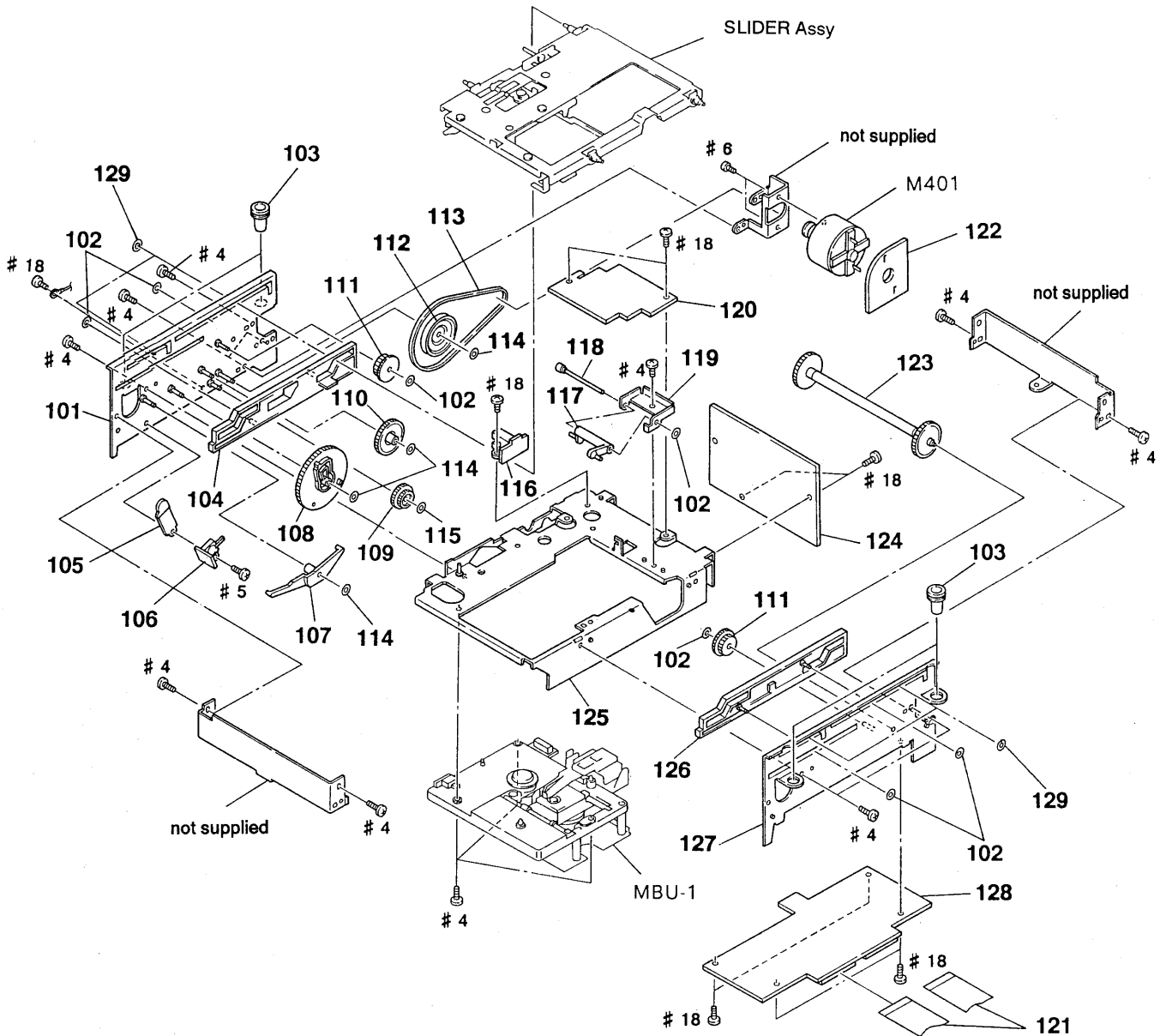

Ref. No.	Part No.	Description
* 101	X-4943-546-1	BRACKET (GUIDE L) ASSY
102	4-957-798-11	WASHER, STOPPER
103	4-957-800-01	DAMPER (MD)
104	X-4943-553-1	RACK (PLATE CAM L) ASSY
* 105	4-957-799-01	BLOCK (SW)
* 106	1-647-652-11	IN/OUT SW BOARD
107	4-957-806-01	LEVER (O/C)
108	4-957-801-01	GEAR (CAM GEAR)
109	4-957-805-01	GEAR (S)
110	4-957-804-01	GEAR (2)
111	4-957-795-01	GEAR (DRIVING)
112	4-957-794-01	PULLEY (GEAR 1)
113	4-957-797-01	BELT (LOADING)
114	3-558-708-21	WASHER, STOPPER
115	3-558-708-01	WASHER, STOPPER

Remark	Ref. No.	Part No.	Description	Remark
	* 116	1-647-653-11	INTERRUPTER BOARD	
	117	4-957-816-01	LEVER (REC LEVER)	
	118	4-957-815-01	SHAFT (REC LEVER)	
	* 119	4-957-814-01	BRACKET (REC LEVER)	
	* 120	A-4649-454-A	H DRIVE BOARD, COMPLETE	
	121	1-751-068-11	WIRE (FLAT TYPE) (24 CORE)	
	* 122	1-647-654-11	LOADING MOTOR BOARD	
	123	A-4660-372-A	SHAFT (JOINT) ASSY	
	* 124	A-4649-658-A	SERVO DRIVE BOARD, COMPLETE	
	* 125	X-4943-552-1	BRACKET (BU) ASSY	
	126	X-4943-551-1	RACK (PLATE CAM R) ASSY	
	* 127	X-4943-547-1	BRACKET (GUIDE R) ASSY	
	* 128	A-4649-450-A	RF BOARD, COMPLETE	
	129	4-957-798-01	WASHER, STOPPER	
	M401	X-4943-555-1	MOTOR ASSY (LOADING)	

5-4. MECHANISM DECK SECTION-2 (SLIDER ASSY)  
(MDM-1A)

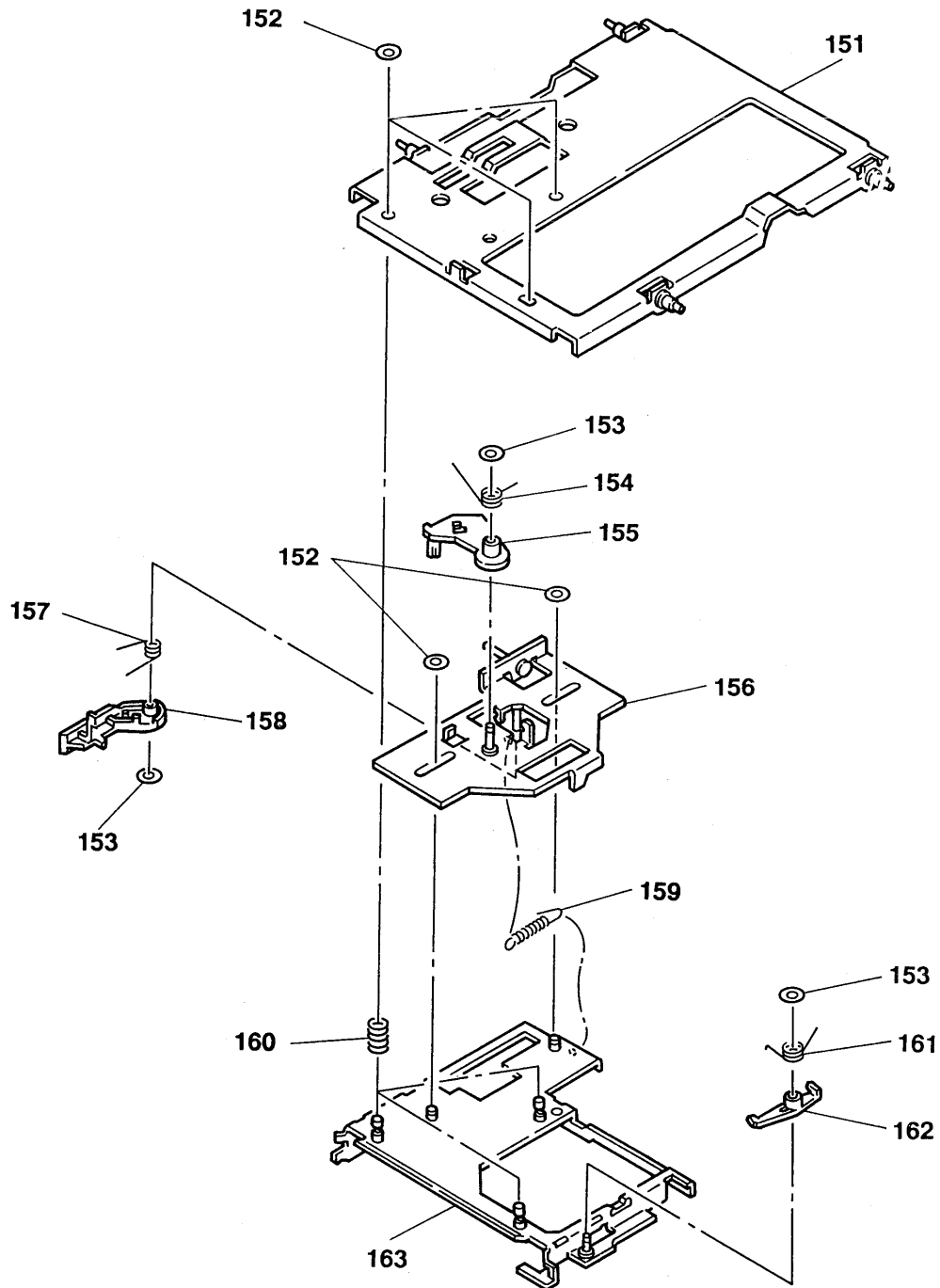

Ref. No.	Part No.	Description	Remark	Ref. No.	Part No.	Description	Remark
* 151	X-4943-549-1	SLIDER ASSY		158	4-957-803-01	LEVER (EJECT)	
152	3-558-708-01	WASHER, STOPPER		159	4-957-811-01	SPRING (EJ SLIDER), TORSION	
153	4-957-798-11	WASHER, STOPPER		160	4-957-808-01	SPRING, COMPRESSION	
154	4-957-810-01	SPRING, TORSION		161	4-957-812-01	SPRING (SHUTTER LEVER), TORSION	
155	4-957-802-01	LEVER (DETECTION)		162	4-958-651-01	LEVER (SHUTTER L)	
* 156	X-4943-550-1	SLIDER (EJECT) ASSY		* 163	X-4943-548-1	HOLDER ASSY	
157	4-957-809-01	SPRING (EJECT LEVER), TORSION					

### 5-5. BASE UNIT SECTION (MBU-1A)

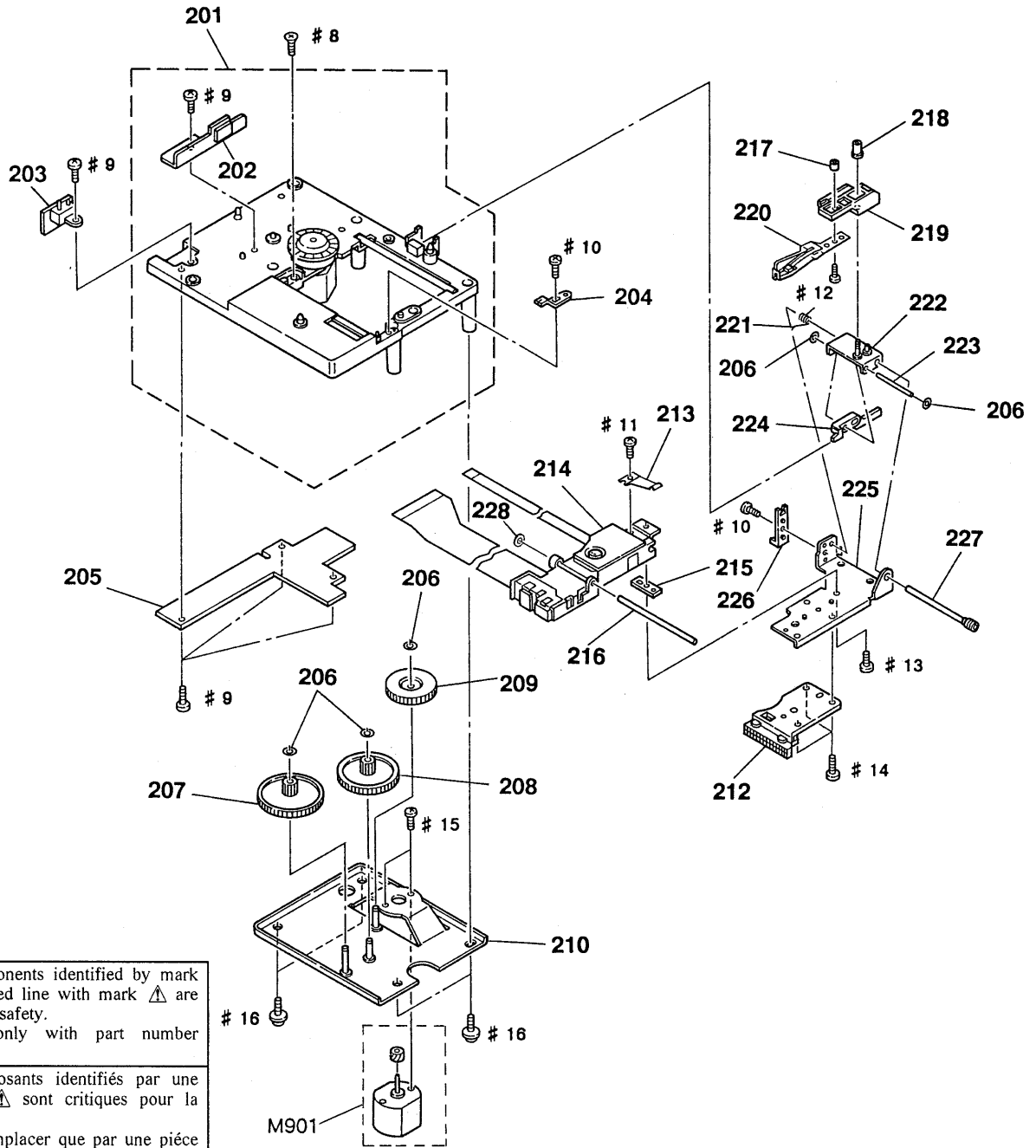

The components identified by mark  $\Delta$  or dotted line with mark  $\Delta$  are critical for safety. Replace only with part number specified.

Les composants identifiés par une marque  $\Delta$  sont critiques pour la sécurité. Ne les remplacer que par une pièce portant le numéro spécifié.

Ref. No.	Part No.	Description	Remark	Ref. No.	Part No.	Description	Remark
201	A-4660-222-A	CHASSIS (BU) COMPLETE ASSY		217	4-957-053-01	NUT (M1.7), FITTING	
202	A-4660-364-A	BRACKET (MAGNET) ASSY		218	4-957-658-01	NUT (M2), FASTENING	
* 203	1-647-658-11	DETECTION SW BOARD		* 219	4-957-054-01	HOLDER (OWH)	
204	4-957-047-01	HOLDER (SHAFT)		220	1-500-006-11	HEAD, OVER WRITE	
* 205	1-647-657-11	BU RELAY BOARD		221	4-957-049-01	SPRING (HOLDER), TORSION	
206	3-681-678-00	WASHER, SLIT		* 222	X-4943-433-1	BRACKET (HOLDER) ASSY	
207	4-957-057-01	GEAR (PINION A)		223	4-957-051-01	SHAFT (SLED D)	
208	4-957-058-01	GEAR (PINION B)		* 224	4-957-061-01	LEVER (OWH)	
209	4-957-059-01	GEAR (PINION C)		* 225	4-957-052-01	BRACKET (RACK)	
* 210	X-4943-431-1	BRACKET (PINION) ASSY		* 226	4-957-055-01	HOLDER (WIRE)	
212	X-4943-432-1	RACK ASSY		227	X-4943-434-1	SCREW ASSY, ADJUSTMENT	
213	4-957-056-01	DETENT (OPTICS BLOCK)		228	4-958-741-01	SPACER	
$\Delta$ 214	8-583-003-21	DEVICE, MINIATURE DISC KMS-140B		M901	X-4944-046-1	MOTOR ASSY, SLED	
215	4-957-048-01	SPACER					
216	4-957-044-01	SHAFT (SLED A)					

# SECTION 6

## ELECTRICAL PARTS LIST



**NOTE:**

The components identified by mark  $\Delta$  or dotted line with mark  $\Delta$  are critical for safety.  
Replace only with part number specified.

Les composants identifiés par une marque  $\Delta$  sont critiques pour la sécurité.  
Ne les remplacer que par une pièce portant le numéro spécifié.

When indicating parts by reference number, please include the board name.

- Due to standardization, replacements in the parts list may be different from the parts specified in the diagrams or the components used on the set.
- -XX, -X mean standardized parts, so they may have some difference from the original one.
- **RESISTORS**  
All resistors are in ohms  
METAL: Metal-film resistor  
METAL OXIDE: Metal Oxide-film resistor  
F : nonflammable
- Items marked "\*" are not stocked since they are seldom required for routine service. Some delay should be anticipated when ordering these items.
- JE : Tourist model
- SP : Singapore model
- Color Indication of Appearance Parts Example:  
KNOB, BALANCE (WHITE) . . . (RED)  

$\uparrow$	Parts color	$\uparrow$	Cabinet's color
------------	-------------	------------	-----------------
- **SEMICONDUCTORS**  
In each case, u:  $\mu$ , for example:  
uA...:  $\mu$  A..., uPA...:  $\mu$  PA...,  
uPB...:  $\mu$  PB..., uPC...:  $\mu$  PC...,  
uPD...:  $\mu$  PD...
- **CAPACITORS**  
uF:  $\mu$  F
- **COILS**  
uH:  $\mu$  H
- Hardware (# mark) list is given in the last of this parts list.

Ref.No.	Part No.	Description	Remark	Ref.No.	Part No.	Description	Remark
*	1-647-641-11	AC BOARD *****		C513	1-126-927-11	ELECT 2200uF 20%	10V
*	3-309-144-31	HEAT SINK		C515	1-104-547-11	FILM CHIP 0.0047uF 5%	16V
*	4-921-402-01	HEAT SINK		C516	1-164-004-11	CERAMIC CHIP 0.1uF 10%	25V
	7-682-547-04	SCREW +B 3X6		C518	1-124-910-11	ELECT 47uF 20%	50V
		< CAPACITOR >		C519	1-104-540-11	FILM CHIP 0.0012uF 5%	50V
$\Delta$ C590	1-161-743-00	CERAMIC 0.0047uF 400V		C525	1-104-539-11	FILM CHIP 0.001uF 5%	50V
		< CONNECTOR >		C527	1-164-004-11	CERAMIC CHIP 0.1uF 10%	25V
* CN591	1-580-230-31	PIN, CONNECTOR (PC BOARD) 2P (US, Canadian, JE, SP)		C531	1-164-004-11	CERAMIC CHIP 0.1uF 10%	25V
* CN591	1-580-230-41	PIN, CONNECTOR (PC BOARD) 2P (AEP, UK)		C532	1-104-539-11	FILM CHIP 0.001uF 5%	50V
* CN592	1-573-279-11	PIN, CONNECTOR 9P		C535	1-104-547-11	FILM CHIP 0.0047uF 5%	16V
		< SWITCH >		C536	1-104-540-11	FILM CHIP 0.0012uF 5%	50V
$\Delta$ SW501	1-572-675-11	SWITCH, POWER VOLTAGE CHANGE (VOLTAGE SELECTOR) (JE, SP)		C540	1-124-910-11	ELECT 47uF 20%	50V
		< TRASFORMER >		C546	1-126-933-11	ELECT 100uF 20%	16V
$\Delta$ T501	1-424-485-11	FILTER, LINE		C547	1-124-443-00	ELECT 100uF 20%	10V
*****				C548	1-124-903-11	ELECT 1uF 20%	50V
*	A-4649-690-A	AUDIO BOARD, COMPLETE (US, Canadian) *****		C549	1-244-360-00	ELECT 1000uF 20%	16V
*	A-4649-694-A	AUDIO BOARD, COMPLETE (AEP, UK, JE, SP) *****		C550	1-124-443-00	ELECT 100uF 20%	10V
		< CAPACITOR >		C551	1-124-903-11	ELECT 1uF 20%	50V
C501	1-164-004-11	CERAMIC CHIP 0.1uF 10%	25V	C552	1-124-903-11	ELECT 1uF 20%	50V
C502	1-126-950-11	ELECT 330uF 20%	35V	C553	1-163-009-11	CERAMIC CHIP 0.001uF 10%	50V
C503	1-124-572-11	ELECT 100uF 20%	63V	C554	1-164-004-11	CERAMIC CHIP 0.1uF 10%	25V
C504	1-164-232-11	CERAMIC CHIP 0.01uF 50V		C556	1-126-233-11	ELECT 22uF 20%	50V
C505	1-164-232-11	CERAMIC CHIP 0.01uF 50V		C557	1-163-105-00	CERAMIC CHIP 33PF 5%	50V
C506	1-104-773-51	ELECT 22000uF 20%	16V	C558	1-124-910-11	ELECT 47uF 20%	50V
C507	1-163-037-11	CERAMIC CHIP 0.022uF 10%	25V	C559	1-163-105-00	CERAMIC CHIP 33PF 5%	50V
C508	1-126-233-11	ELECT 22uF 20%	50V	C561	1-124-910-11	ELECT 47uF 20%	50V
C509	1-124-915-11	ELECT 10uF 20%	63V	C562	1-164-004-11	CERAMIC CHIP 0.1uF 10%	25V
C510	1-126-937-11	ELECT 4700uF 20%	16V	C563	1-126-233-11	ELECT 22uF 20%	50V
C511	1-124-443-00	ELECT 100uF 20%	10V	C570	1-164-004-11	CERAMIC CHIP 0.1uF 10%	25V
C512	1-104-748-11	ELECT 15000uF 20%	16V	C571	1-163-009-11	CERAMIC CHIP 0.001uF 10%	50V
				C572	1-124-126-00	ELECT 47uF 20%	10V
				C573	1-124-126-00	ELECT 47uF 20%	10V
				C574	1-164-004-11	CERAMIC CHIP 0.1uF 10%	25V
				C580	1-124-477-11	ELECT 47uF 20%	25V
				C581	1-124-477-11	ELECT 47uF 20%	25V
				C582	1-164-004-11	CERAMIC CHIP 0.1uF 10%	25V
				C585	1-164-004-11	CERAMIC CHIP 0.1uF 10%	25V
				C595	1-126-935-11	ELECT 470uF 20%	16V
				C596	1-124-443-00	ELECT 100uF 20%	10V
				C597	1-124-443-00	ELECT 100uF 20%	10V
				C598	1-164-004-11	CERAMIC 0.1uF 10%	25V
				C599	1-164-004-11	CERAMIC 0.1uF 10%	25V

# AUDIO

Ref.No.	Part No.	Description	Remark	Ref.No.	Part No.	Description	Remark
< CONNECTOR >				△ICP506 1-532-839-11 LINK, IC PRF1000, 1.0A (AEP, UK, JE, SP)			
* CN504	1-750-491-31	PIN, CONNECTOR (PC BOARD) 3P		< JACK >			
* CN506	1-695-241-31	PIN, CONNECTOR (PC BOARD) 8P		J501	1-573-520-11	JACK, PIN 4P (LINE IN/OUT)	
* CN507	1-750-492-31	PIN, CONNECTOR (PC BOARD) 4P		< COIL >			
* CNP503	1-564-666-51	PIN, CONNECTOR 10P		L501	1-410-393-11	INDUCTOR CHIP 100uH	
* CNP509	1-564-710-11	PIN, CONNECTOR (PC BOARD) 8P		L502	1-543-962-11	BEAD, FERRITE (CHIP)	
* CNP510	1-691-998-11	PIN, CONNECTOR (PC BOARD) 9P		L503	1-543-962-11	BEAD, FERRITE (CHIP)	
* CNP511	1-691-995-31	PIN, CONNECTOR (PC BOARD) 6P		< TRANSISTOR >			
* CNP512	1-565-561-11	PIN, CONNECTOR 3P (AU BUS)		Q501	8-729-808-01	TRANSISTOR 2SD1622-S	
< DIODE >				Q502	8-729-901-06	TRANSISTOR DTA144EK	
D501	8-719-016-74	DIODE 1SS352		Q503	8-729-107-46	TRANSISTOR 2SC3624A-L15	
D502	8-719-801-78	DIODE 1SS184		Q504	8-729-107-46	TRANSISTOR 2SC3624A-L15	
D504	8-719-422-43	DIODE MA8051-H		Q506	8-729-901-06	TRANSISTOR DTA144EK	
D505	8-719-210-33	DIODE EC10DS2		Q507	8-729-421-19	TRANSISTOR UN2213	
D506	8-719-031-60	DIODE EA40QC04F		Q508	8-729-620-06	TRANSISTOR 2SC3052-EF	
D507	8-719-016-74	DIODE 1SS352		Q509	8-729-620-06	TRANSISTOR 2SC3052-EF	
D508	8-719-820-05	DIODE 1SS181		Q510	8-729-620-06	TRANSISTOR 2SC3052-EF	
D509	8-719-016-74	DIODE 1SS352		Q511	8-729-421-19	TRANSISTOR UN2213	
D510	8-719-210-39	DIODE EC10QS-04		Q512	8-729-901-06	TRANSISTOR DTA144EK	
D511	8-719-210-39	DIODE EC10QS-04		< RESISTOR >			
D512	8-719-210-39	DIODE EC10QS-04		R501	1-216-691-11	METAL CHIP 47K 0.5% 1/10W	
D513	8-719-210-39	DIODE EC10QS-04		R502	1-216-675-11	METAL CHIP 10K 0.5% 1/10W	
D514	8-719-016-74	DIODE 1SS352		R503	1-216-627-11	METAL CHIP 100 0.5% 1/10W	
D515	8-719-210-39	DIODE EC10QS-04		R504	1-218-764-11	METAL CHIP 330K 0.5% 1/10W	
D516	8-719-210-39	DIODE EC10QS-04		R505	1-216-691-11	METAL CHIP 47K 0.5% 1/10W	
D517	8-719-210-33	DIODE EC10DS2		R506	1-216-651-11	METAL CHIP 1K 0.5% 1/10W	
D518	8-719-210-33	DIODE EC10DS2		R508	1-216-665-11	METAL CHIP 3.9K 0.5% 1/10W	
D519	8-719-820-05	DIODE 1SS181		R509	1-216-691-11	METAL CHIP 47K 0.5% 1/10W	
< FUSE >				R510	1-216-661-11	METAL CHIP 2.7K 0.5% 1/10W	
△F504	1-532-776-21	FUSE, MICRO (1A) (SECONDARY) (US, Canadian)		R513	1-216-643-11	METAL CHIP 470 0.5% 1/10W	
△F505	1-532-776-21	FUSE, MICRO (1A) (SECONDARY) (US, Canadian)		R514	1-218-760-11	METAL CHIP 220K 0.5% 1/10W	
△F506	1-532-776-21	FUSE, MICRO (1A) (SECONDARY) (US, Canadian)		R515	1-216-655-11	METAL CHIP 1.5K 0.5% 1/10W	
< IC >				R516	1-216-655-11	METAL CHIP 1.5K 0.5% 1/10W	
IC501	8-759-633-42	IC M5293L		R521	1-216-667-11	METAL CHIP 4.7K 0.5% 1/10W	
IC502	8-759-242-70	IC TC7WU04F		R522	1-216-661-11	METAL CHIP 2.7K 0.5% 1/10W	
IC503	8-759-925-54	IC LM2940CT-5.0		R523	1-216-675-11	METAL CHIP 10K 0.5% 1/10W	
IC504	8-759-925-54	IC LM2940CT-5.0		R524	1-216-699-11	METAL CHIP 100K 0.5% 1/10W	
IC508	8-759-982-04	IC RC5532M		R525	1-216-643-11	METAL CHIP 470 0.5% 1/10W	
IC509	8-759-631-40	IC M5294P		R526	1-216-619-11	METAL CHIP 47 0.5% 1/10W	
IC511	8-759-114-06	IC uPC814G2-1		R530	1-216-643-11	METAL CHIP 470 0.5% 1/10W	
IC513	8-749-921-12	IC GPIF32T (DIGITAL OUT)		R531	1-216-661-11	METAL CHIP 2.7K 0.5% 1/10W	
IC514	8-749-921-11	IC GPIF32R (DIGITAL IN)		R532	1-216-675-11	METAL CHIP 10K 0.5% 1/10W	
IC516	8-759-981-86	IC RC4556MA		R533	1-216-619-11	METAL CHIP 47 0.5% 1/10W	
< IC LINK >				R534	1-218-760-11	METAL CHIP 220K 0.5% 1/10W	
△ICP504	1-532-839-11	LINK, IC PRF1000, 1.0A (AEP, UK, JE, SP)		R535	1-216-667-11	METAL CHIP 4.7K 0.5% 1/10W	
△ICP505	1-532-839-11	LINK, IC PRF1000, 1.0A (AEP, UK, JE, SP)					

The components identified by mark △ or dotted line with mark △ are critical for safety. Replace only with part number specified.	Les composants identifiés par une marque △ sont critiques pour la sécurité. Ne les remplacer que par une pièce portant le numéro spécifié.
---	---



**AUDIO**

**BU RELAY**

**DETECTION SW**

**DIGITAL**

Ref.No.	Part No.	Description	Remark
R539	1-216-643-11	METAL CHIP 470 0.5% 1/10W	
R540	1-216-655-11	METAL CHIP 1.5K 0.5% 1/10W	
R541	1-216-655-11	METAL CHIP 1.5K 0.5% 1/10W	
R544	1-216-685-11	METAL CHIP 27K 0.5% 1/10W	
R545	1-216-691-11	METAL CHIP 47K 0.5% 1/10W	
R547	1-216-685-11	METAL CHIP 27K 0.5% 1/10W	
R548	1-216-603-11	METAL CHIP 10 0.5% 1/10W	
R549	1-216-687-11	METAL CHIP 33K 0.5% 1/10W	
R550	1-216-663-11	METAL CHIP 3.3K 0.5% 1/10W	
R551	1-216-699-11	METAL CHIP 100K 0.5% 1/10W	
R552	1-216-699-11	METAL CHIP 100K 0.5% 1/10W	
R553	1-216-663-11	METAL CHIP 3.3K 0.5% 1/10W	
R554	1-216-687-11	METAL CHIP 33K 0.5% 1/10W	
R556	1-216-603-11	METAL CHIP 10 0.5% 1/10W	
R557	1-216-691-11	METAL CHIP 47K 0.5% 1/10W	
R558	1-216-667-11	METAL CHIP 4.7K 0.5% 1/10W	
R559	1-216-675-11	METAL CHIP 10K 0.5% 1/10W	
R560	1-216-603-11	METAL CHIP 10 0.5% 1/10W	
R571	1-216-677-11	METAL CHIP 12K 0.5% 1/10W	
R572	1-216-677-11	METAL CHIP 12K 0.5% 1/10W	
R573	1-216-687-11	METAL CHIP 33K 0.5% 1/10W	
R574	1-216-295-00	METAL CHIP 0 5% 1/8W	
R575	1-216-619-11	METAL CHIP 47 0.5% 1/10W	
R576	1-216-295-00	METAL CHIP 0 5% 1/8W	
R577	1-216-687-11	METAL CHIP 33K 0.5% 1/10W	
R578	1-216-619-11	METAL CHIP 47 0.5% 1/10W	
R579	1-216-643-11	METAL CHIP 470 0.5% 1/10W	
R580	1-216-667-11	METAL CHIP 4.7K 0.5% 1/10W	
R581	1-216-643-11	METAL CHIP 470 0.5% 1/10W	
R582	1-216-667-11	METAL CHIP 4.7K 0.5% 1/10W	
R583	1-216-699-11	METAL CHIP 100K 0.5% 1/10W	
R584	1-216-627-11	METAL CHIP 100 0.5% 1/10W	
R586	1-216-691-11	METAL CHIP 47K 0.5% 1/10W	
		< RELAY >	
RY501	1-515-719-11	RELAY	
RY502	1-515-925-11	RELAY	
*****			
*	1-647-647-11	BU RELAY BOARD	
		*****	
		< CONNECTOR >	
CN200	1-750-501-21	PIN, CONNECTOR (PC BOARD) 8P	
		< SWITCH >	
S901	1-572-467-11	SWITCH, PUSH (1 KEY) (LIMIT)	
*****			

Ref.No.	Part No.	Description	Remark
*	1-647-648-11	DETECTION SW BOARD	
		*****	
		< SWITCH >	
S001	1-692-464-11	SWITCH, PUSH (2 KEY) (RFLCT/PROT)	
*****			
*	A-4649-446-A	DIGITAL BOARD, COMPLETE	
		*****	
		< CAPACITOR >	
C100	1-126-204-11	ELECT CHIP 47uF 20% 16V	
C101	1-164-004-11	CERAMIC CHIP 0.1uF 10% 25V	
C102	1-164-004-11	CERAMIC CHIP 0.1uF 10% 25V	
C103	1-164-004-11	CERAMIC CHIP 0.1uF 10% 25V	
C104	1-164-004-11	CERAMIC CHIP 0.1uF 10% 25V	
C105	1-164-004-11	CERAMIC CHIP 0.1uF 10% 25V	
C106	1-164-004-11	CERAMIC CHIP 0.1uF 10% 25V	
C107	1-164-232-11	CERAMIC CHIP 0.01uF 50V	
C108	1-164-004-11	CERAMIC CHIP 0.1uF 10% 25V	
C109	1-164-232-11	CERAMIC CHIP 0.01uF 50V	
C110	1-164-004-11	CERAMIC CHIP 0.1uF 10% 25V	
C111	1-126-206-11	ELECT CHIP 100uF 20% 6.3V	
C112	1-164-004-11	CERAMIC CHIP 0.1uF 10% 25V	
C113	1-126-204-11	ELECT CHIP 47uF 20% 16V	
C114	1-126-204-11	ELECT CHIP 47uF 20% 16V	
C115	1-164-004-11	CERAMIC CHIP 0.1uF 10% 25V	
C116	1-164-004-11	CERAMIC CHIP 0.1uF 10% 25V	
C117	1-164-004-11	CERAMIC CHIP 0.1uF 10% 25V	
C118	1-164-004-11	CERAMIC CHIP 0.1uF 10% 25V	
C119	1-164-004-11	CERAMIC CHIP 0.1uF 10% 25V	
C120	1-126-206-11	ELECT CHIP 100uF 20% 6.3V	
C121	1-163-241-11	CERAMIC CHIP 39PF 5% 50V	
C122	1-163-009-11	CERAMIC CHIP 0.001uF 10% 50V	
C123	1-164-004-11	CERAMIC CHIP 0.1uF 10% 25V	
C124	1-163-009-11	CERAMIC CHIP 0.001uF 10% 50V	
C125	1-104-563-11	FILM CHIP 0.1uF 5% 16V	
C126	1-164-004-11	CERAMIC CHIP 0.1uF 10% 25V	
C128	1-163-091-00	CERAMIC CHIP 8PF 50V	
C129	1-163-091-00	CERAMIC CHIP 8PF 50V	
C130	1-164-004-11	CERAMIC CHIP 0.1uF 10% 25V	
C131	1-104-640-11	FILM CHIP 0.22uF 5% 16V	
C132	1-163-037-11	CERAMIC CHIP 0.022uF 10% 25V	
C133	1-164-004-11	CERAMIC CHIP 0.1uF 10% 25V	
C134	1-137-299-11	FILM CHIP 0.027uF 5% 16V	
C135	1-164-232-11	CERAMIC CHIP 0.01uF 50V	
C136	1-164-004-11	CERAMIC CHIP 0.1uF 10% 25V	
C137	1-126-206-11	ELECT CHIP 100uF 20% 6.3V	
C138	1-126-204-11	ELECT CHIP 47uF 20% 16V	
C139	1-164-004-11	CERAMIC CHIP 0.1uF 10% 25V	

# DIGITAL

Ref. No.	Part No.	Description	Remark	Ref. No.	Part No.	Description	Remark
C140	1-164-232-11	CERAMIC CHIP 0.01uF	50V	C538	1-164-004-11	CERAMIC CHIP 0.1uF 10%	25V
C141	1-164-004-11	CERAMIC CHIP 0.1uF	10% 25V	C539	1-126-204-11	ELECT CHIP 47uF	20% 16V
C142	1-126-204-11	ELECT CHIP 47uF	20% 16V	C541	1-126-204-11	ELECT CHIP 47uF	20% 16V
C143	1-164-004-11	CERAMIC CHIP 0.1uF	10% 25V	C542	1-164-004-11	CERAMIC CHIP 0.1uF	10% 25V
C144	1-164-232-11	CERAMIC CHIP 0.01uF	50V	C543	1-164-004-11	CERAMIC CHIP 0.1uF	10% 25V
C145	1-126-204-11	ELECT CHIP 47uF	20% 16V	C544	1-126-204-11	ELECT CHIP 47uF	20% 16V
C146	1-164-004-11	CERAMIC CHIP 0.1uF	10% 25V	C555	1-104-551-11	FILM CHIP 0.01uF	5% 16V
C147	1-126-204-11	ELECT CHIP 47uF	20% 16V	C560	1-104-551-11	FILM CHIP 0.01uF	5% 16V
C148	1-164-161-11	CERAMIC CHIP 0.0022uF	10% 100V	C561	1-163-093-00	CERAMIC CHIP 10PF	5% 50V
C149	1-164-161-11	CERAMIC CHIP 0.0022uF	10% 10V	C564	1-164-004-11	CERAMIC CHIP 0.1uF	10% 25V
C150	1-164-004-11	CERAMIC CHIP 0.1uF	10% 25V	C565	1-164-004-11	CERAMIC CHIP 0.1uF	10% 25V
C151	1-163-117-00	CERAMIC CHIP 100PF	5% 50V	C566	1-164-004-11	CERAMIC CHIP 0.1uF	10% 25V
C153	1-126-204-11	ELECT CHIP 47uF	20% 16V	C567	1-126-204-11	ELECT CHIP 47uF	20% 16V
C154	1-164-004-11	CERAMIC CHIP 0.1uF	10% 25V	C568	1-126-204-11	ELECT CHIP 47uF	20% 16V
C158	1-164-004-11	CERAMIC CHIP 0.1uF	10% 25V	C569	1-124-779-00	ELECT CHIP 10uF	20% 16V
C159	1-126-204-11	ELECT CHIP 47uF	20% 16V	C583	1-104-559-11	FILM CHIP 0.047uF	5% 16V
C160	1-104-551-11	FILM CHIP 0.01uF	5% 16V	C584	1-104-559-11	FILM CHIP 0.047uF	5% 16V
C161	1-163-003-11	CERAMIC CHIP 330PF	10% 50V			< CONNECTOR >	
C162	1-164-344-11	CERAMIC CHIP 0.068uF	10% 25V			* CNP101 1-750-511-21 CONNECTOR, FFC/FPC 24P	
C163	1-126-395-11	ELECT 22uF	20% 16V			* CNP102 1-750-511-21 CONNECTOR, FFC/FPC 24P	
C164	1-164-004-11	CERAMIC CHIP 0.1uF	10% 25V			* CNP103 1-750-495-31 PIN, CONNECTOR (PC BOARD) 7P	
C165	1-126-395-11	ELECT 22uF	20% 16V			* CNP104 1-750-492-31 PIN, CONNECTOR (PC BOARD) 4P	
C166	1-126-395-11	ELECT 22uF	20% 16V			* CNP105 1-695-241-31 PIN, CONNECTOR (PC BOARD) 8P	
C167	1-163-017-00	CERAMIC CHIP 0.0047uF	5% 50V			* CNP108 1-750-494-11 PIN, CONNECTOR (PC BOARD) 6P	
C168	1-163-117-00	CERAMIC CHIP 100PF	5% 50V			< DIODE >	
C169	1-104-559-11	FILM CHIP 0.047uF	5% 16V	D102	8-719-974-98	DIODE HVM17-01	
C170	1-163-009-11	CERAMIC CHIP 0.001uF	10% 50V	D103	8-719-016-74	DIODE 1SS352	
C185	1-164-161-11	CERAMIC CHIP 0.0022uF	10% 100V	D104	8-719-016-74	DIODE 1SS352	
C187	1-164-004-11	CERAMIC CHIP 0.1uF	10% 25V			< IC >	
C201	1-163-117-00	CERAMIC CHIP 100PF	5% 50V	IC101	8-752-355-96	IC CXD2527R	
C202	1-163-117-00	CERAMIC CHIP 100PF	5% 50V	IC102	8-752-356-18	IC CXD2527R-1	
C301	1-164-004-11	CERAMIC CHIP 0.1uF	10% 25V	IC103	8-752-352-18	IC CXD2525R	
C303	1-164-004-11	CERAMIC CHIP 0.1uF	10% 25V	IC104	8-759-242-70	IC TC7WU04F	
C305	1-164-004-11	CERAMIC CHIP 0.1uF	10% 25V	IC106	8-759-970-59	IC TLC272CPS	
C306	1-164-004-11	CERAMIC CHIP 0.1uF	10% 25V	IC109	8-759-096-83	IC M5M44400ATP-8L	
C307	1-164-004-11	CERAMIC CHIP 0.1uF	10% 25V	IC110	8-752-354-57	IC CXD2526Q	
C308	1-164-004-11	CERAMIC CHIP 0.1uF	10% 25V	IC111	8-759-095-49	IC M38067M8-051FP	
C516	1-163-104-00	CERAMIC CHIP 30PF	5% 50V	IC161	8-752-064-33	IC CXA1380N	
C517	1-163-115-00	CERAMIC CHIP 82PF	5% 50V	IC191	8-759-083-94	IC TC7W74FU	
C520	1-164-004-11	CERAMIC CHIP 0.1uF	10% 25V	IC192	8-759-234-13	IC TC4S30F	
C521	1-126-204-11	ELECT CHIP 47uF	20% 16V	IC505	8-752-355-44	IC CXD2564M	
C523	1-163-104-00	CERAMIC CHIP 30PF	5% 50V	IC507	8-759-981-48	IC RC082M2G2	
C524	1-163-115-00	CERAMIC CHIP 82PF	5% 50V	IC510	8-759-045-15	IC CS5339-KS	
C526	1-164-004-11	CERAMIC CHIP 0.1uF	10% 25V			< JUMPER RESISTOR >	
C527	1-164-004-11	CERAMIC CHIP 0.1uF	10% 25V	JW121	1-216-295-00	METAL CHIP 0 5% 1/10W	
C528	1-164-004-11	CERAMIC CHIP 0.1uF	10% 25V				
C529	1-126-204-11	ELECT CHIP 47uF	20% 16V				
C530	1-164-004-11	CERAMIC CHIP 0.1uF	10% 25V				
C534	1-163-104-00	CERAMIC CHIP 30PF	5% 50V				
C537	1-163-104-00	CERAMIC CHIP 30PF	5% 50V				

Ref. No.	Part No.	Description	Remark	Ref. No.	Part No.	Description	Remark
JW201	1-216-295-00	METAL CHIP	0 5% 1/10W	R124	1-216-073-00	METAL CHIP	10K 5% 1/10W
JW202	1-216-295-00	METAL CHIP	0 5% 1/10W	R125	1-216-073-00	METAL CHIP	10K 5% 1/10W
JW205	1-216-295-00	METAL CHIP	0 5% 1/10W	R126	1-216-073-00	METAL CHIP	10K 5% 1/10W
< COIL >				R127	1-216-043-00	METAL CHIP	560 5% 1/10W
L101	1-412-333-41	INDUCTOR	2. 7uH	R128	1-216-043-00	METAL CHIP	560 5% 1/10W
L102	1-412-332-41	INDUCTOR	2. 2uH	R129	1-216-043-00	METAL CHIP	560 5% 1/10W
L103	1-412-332-41	INDUCTOR	2. 2uH	R130	1-216-073-00	METAL CHIP	10K 5% 1/10W
L104	1-412-340-31	INDUCTOR	10uH	R131	1-216-073-00	METAL CHIP	10K 5% 1/10W
L105	1-412-344-31	INDUCTOR	22uH	R132	1-216-073-00	METAL CHIP	10K 5% 1/10W
L106	1-412-340-31	INDUCTOR	10uH	R133	1-216-070-00	METAL CHIP	7. 5K 5% 1/10W
L107	1-412-340-31	INDUCTOR	10uH	R134	1-216-081-00	METAL CHIP	22K 5% 1/10W
L108	1-412-336-41	INDUCTOR	4. 7uH	R135	1-216-073-00	METAL CHIP	10K 5% 1/10W
L109	1-412-332-41	INDUCTOR	2. 2uH	R136	1-216-073-00	METAL CHIP	10K 5% 1/10W
L150	1-543-962-21	BEAD, FERRITE (CHIP)		R137	1-216-073-00	METAL CHIP	10K 5% 1/10W
L151	1-550-907-21	BEAD, FERRITE (CHIP)		R138	1-216-073-00	METAL CHIP	10K 5% 1/10W
L152	1-543-962-21	BEAD, FERRITE (CHIP)		R139	1-216-073-00	METAL CHIP	10K 5% 1/10W
L153	1-543-963-21	BEAD, FERRITE (CHIP)		R140	1-216-043-00	METAL CHIP	560 5% 1/10W
L501	1-412-336-41	INDUCTOR	4. 7uH	R141	1-216-073-00	METAL CHIP	10K 5% 1/10W
L502	1-410-387-11	INDUCTOR CHIP	33uH	R142	1-216-073-00	METAL CHIP	10K 5% 1/10W
L503	1-412-336-41	INDUCTOR	4. 7uH	R144	1-216-073-00	METAL CHIP	10K 5% 1/10W
L504	1-412-336-41	INDUCTOR	4. 7uH	R145	1-216-025-00	METAL CHIP	100 5% 1/10W
L505	1-412-332-41	INDUCTOR	2. 2uH	R146	1-216-049-00	METAL CHIP	1K 5% 1/10W
L506	1-412-332-41	INDUCTOR	2. 2uH	R147	1-216-045-00	METAL CHIP	680 5% 1/10W
L507	1-412-336-41	INDUCTOR	4. 7uH	R148	1-216-081-00	METAL CHIP	22K 5% 1/10W
< TRANSISTOR >				R149	1-216-081-00	METAL CHIP	22K 5% 1/10W
Q101	8-729-421-19	TRANSISTOR	UN2213	R150	1-216-081-00	METAL CHIP	22K 5% 1/10W
Q102	8-729-901-06	TRANSISTOR	DTA144EK	R151	1-216-073-00	METAL CHIP	10K 5% 1/10W
Q505	8-729-421-19	TRANSISTOR	UN2213	R152	1-216-073-00	METAL CHIP	10K 5% 1/10W
< RESISTOR >				R153	1-216-073-00	METAL CHIP	10K 5% 1/10W
R100	1-216-033-00	METAL CHIP	220 5% 1/10W	R154	1-216-073-00	METAL CHIP	10K 5% 1/10W
R101	1-216-057-00	METAL CHIP	2. 2K 5% 1/10W	R155	1-216-073-00	METAL CHIP	10K 5% 1/10W
R102	1-216-057-00	METAL CHIP	2. 2K 5% 1/10W	R156	1-216-073-00	METAL CHIP	10K 5% 1/10W
R103	1-216-073-00	METAL CHIP	10K 5% 1/10W	R157	1-216-073-00	METAL CHIP	10K 5% 1/10W
R104	1-216-081-00	METAL CHIP	22K 5% 1/10W	R158	1-216-073-00	METAL CHIP	10K 5% 1/10W
R107	1-216-073-00	METAL CHIP	10K 5% 1/10W	R159	1-216-073-00	METAL CHIP	10K 5% 1/10W
R108	1-216-073-00	METAL CHIP	10K 5% 1/10W	R160	1-216-073-00	METAL CHIP	10K 5% 1/10W
R109	1-216-073-00	METAL CHIP	10K 5% 1/10W	R161	1-218-758-11	METAL CHIP	180K 0. 5% 1/10W
R110	1-216-073-00	METAL CHIP	10K 5% 1/10W	R162	1-216-083-00	METAL CHIP	27K 5% 1/10W
R111	1-216-073-00	METAL CHIP	10K 5% 1/10W	R163	1-216-121-00	METAL CHIP	1M 5% 1/10W
R112	1-216-073-00	METAL CHIP	10K 5% 1/10W	R164	1-218-758-11	METAL CHIP	180K 0. 5% 1/10W
R113	1-216-073-00	METAL CHIP	10K 5% 1/10W	R165	1-216-121-00	METAL CHIP	1M 5% 1/10W
R117	1-216-121-00	METAL CHIP	1M 5% 1/10W	R166	1-216-112-00	METAL CHIP	430K 5% 1/10W
R118	1-216-049-00	METAL CHIP	1K 5% 1/10W	R167	1-216-090-00	METAL CHIP	51K 5% 1/10W
R119	1-216-049-00	METAL CHIP	1K 5% 1/10W	R168	1-216-073-00	METAL CHIP	10K 5% 1/10W
R120	1-216-077-00	METAL CHIP	15K 5% 1/10W	R169	1-216-073-00	METAL CHIP	10K 5% 1/10W
R121	1-216-077-00	METAL CHIP	15K 5% 1/10W	R170	1-216-073-00	METAL CHIP	10K 5% 1/10W
R122	1-216-073-00	METAL CHIP	10K 5% 1/10W	R171	1-216-073-00	METAL CHIP	10K 5% 1/10W
R123	1-216-073-00	METAL CHIP	10K 5% 1/10W	R172	1-216-073-00	METAL CHIP	10K 5% 1/10W
				R173	1-216-073-00	METAL CHIP	10K 5% 1/10W
				R174	1-216-073-00	METAL CHIP	10K 5% 1/10W

# DIGITAL

# DISP

Ref. No.	Part No.	Description	Remark	Ref. No.	Part No.	Description	Remark
R175	1-216-073-00	METAL CHIP	10K 5% 1/10W			< CAPACITOR >	
R176	1-216-081-00	METAL CHIP	22K 5% 1/10W	C301	1-163-035-00	CERAMIC CHIP 0.047uF	50V
R180	1-216-025-00	METAL CHIP	100 5% 1/10W	C302	1-163-117-00	CERAMIC CHIP 100PF	5% 50V
R181	1-216-065-00	METAL CHIP	4.7K 5% 1/10W	C303	1-164-004-11	CERAMIC CHIP 0.1uF	10% 25V
R182	1-216-065-00	METAL CHIP	4.7K 5% 1/10W	C304	1-126-205-11	ELECT CHIP 47uF	20% 6.3V
R183	1-216-065-00	METAL CHIP	4.7K 5% 1/10W	C305	1-163-009-11	CERAMIC CHIP 0.001uF	10% 50V
R184	1-216-049-00	METAL CHIP	1K 5% 1/10W	C306	1-163-099-00	CERAMIC CHIP 18PF	5% 50V
R185	1-216-049-00	METAL CHIP	1K 5% 1/10W	C307	1-163-234-11	CERAMIC CHIP 20PF	5% 50V
R186	1-216-049-00	METAL CHIP	1K 5% 1/10W	C308	1-126-205-11	ELECT CHIP 47uF	20% 6.3V
R192	1-216-073-00	METAL CHIP	10K 5% 1/10W	C309	1-164-004-11	CERAMIC CHIP 0.1uF	10% 25V
R194	1-216-073-00	METAL CHIP	10K 5% 1/10W	C310	1-164-004-11	CERAMIC CHIP 0.1uF	10% 25V
R195	1-216-073-00	METAL CHIP	10K 5% 1/10W	C311	1-125-486-11	DOUBLE LAYERS 0.22F	5.5V
R196	1-216-073-00	METAL CHIP	10K 5% 1/10W	C312	1-164-004-11	CERAMIC CHIP 0.1uF	10% 25V
R197	1-216-073-00	METAL CHIP	10K 5% 1/10W	C313	1-164-004-11	CERAMIC CHIP 0.1uF	10% 25V
R198	1-216-073-00	METAL CHIP	10K 5% 1/10W	C314	1-164-004-11	CERAMIC CHIP 0.1uF	10% 25V
R201	1-216-295-00	METAL CHIP	0 5% 1/10W	C315	1-164-004-11	CERAMIC CHIP 0.1uF	10% 25V
R202	1-216-097-00	METAL CHIP	100K 5% 1/10W	C316	1-163-035-00	CERAMIC CHIP 0.047uF	50V
R203	1-216-097-00	METAL CHIP	100K 5% 1/10W	C317	1-163-035-00	CERAMIC CHIP 0.047uF	50V
R511	1-216-694-11	METAL CHIP	62K 0.5% 1/10W	C318	1-126-395-11	ELECT 22uF	20% 16V
R512	1-216-681-11	METAL CHIP	18K 0.5% 1/10W	C319	1-163-009-11	CERAMIC 0.001uF	10% 50V
R519	1-216-694-11	METAL CHIP	62K 0.5% 1/10W	C320	1-164-004-11	CERAMIC 0.1uF	10% 25V
R520	1-216-681-11	METAL CHIP	18K 0.5% 1/10W	C374	1-164-294-31	CERAMIC 0.001uF	10% 50V
R522	1-216-635-11	METAL CHIP	220 0.5% 1/10W	C375	1-163-009-11	CERAMIC 0.001uF	10% 50V
R523	1-216-627-11	METAL CHIP	100 0.5% 1/10W	C376	1-163-009-11	CERAMIC 0.001uF	10% 50V
R529	1-216-694-11	METAL CHIP	62K 0.5% 1/10W	C377	1-163-009-11	CERAMIC 0.001uF	10% 50V
R531	1-216-687-11	METAL CHIP	33K 0.5% 1/10W	C378	1-164-004-11	CERAMIC 0.1uF	10% 25V
R532	1-216-687-11	METAL CHIP	33K 0.5% 1/10W			< CONNECTOR >	
R533	1-216-694-11	METAL CHIP	62K 0.5% 1/10W	* CN302	1-695-123-11	PIN, CONNECTOR (PC BOARD) 6P	
R536	1-216-687-11	METAL CHIP	33K 0.5% 1/10W			< DIODE >	
R537	1-216-687-11	METAL CHIP	33K 0.5% 1/10W	D301	8-719-016-74	DIODE 1SS352	
R538	1-216-681-11	METAL CHIP	18K 0.5% 1/10W			< FILTER >	
R543	1-216-681-11	METAL CHIP	18K 0.5% 1/10W	FL301	1-517-112-11	INDICATOR TUBE, FLUORESCENT	
R546	1-216-675-11	METAL CHIP	10K 0.5% 1/10W			< IC >	
R548	1-216-015-00	METAL CHIP	39 5% 1/10W	IC301	8-759-095-48	IC M38003M6-050FP	
R555	1-216-620-11	METAL CHIP	51 0.5% 1/10W	IC302	8-759-164-44	IC CXD8459M	
R556	1-216-015-00	METAL CHIP	39 5% 1/10W	IC303	8-759-504-23	IC RF5C62	
		< VIBRATOR >		IC304	8-749-923-64	IC NJH32H400	
X101	1-579-871-21	VIBRATOR, CRYSTAL (55MHz)		IC305	8-759-926-06	IC SN74HC126ANS	
X102	1-579-870-21	VIBRATOR, CRYSTAL (22.5792MHz)		IC306	8-759-927-46	IC SN74HC00ANS	
X103	1-579-951-11	VIBRATOR, CERAMIC (CHIP TYPE) (6MHz)				< RESISTOR >	
*****				R301	1-216-083-00	METAL CHIP 27K 5% 1/10W	
A-4649-693-A	DISP BOARD, COMPLETE (US, Canadian, JE, SP)			R303	1-216-097-00	METAL CHIP 100K 5% 1/10W	
	*****			R304	1-216-097-00	METAL CHIP 100K 5% 1/10W	
A-4649-697-A	DISP BOARD, COMPLETE (AEP, UK)			R305	1-216-097-00	METAL CHIP 100K 5% 1/10W	
	*****						
*	4-956-134-01	HOLDER (FL TUBE)					

**DISP**

**HEAD DRIVE**

Ref. No.	Part No.	Description	Remark
R306	1-216-097-00	METAL CHIP	100K 5% 1/10W
R307	1-216-097-00	METAL CHIP	100K 5% 1/10W
R308	1-216-097-00	METAL CHIP	100K 5% 1/10W
R309	1-216-097-00	METAL CHIP	100K 5% 1/10W
R310	1-216-097-00	METAL CHIP	100K 5% 1/10W
R311	1-216-073-00	METAL CHIP	10K 5% 1/10W
R312	1-216-041-00	METAL CHIP	470 5% 1/10W
R313	1-216-041-00	METAL CHIP	470 5% 1/10W
R314	1-216-097-00	METAL CHIP	100K 5% 1/10W
R315	1-216-097-00	METAL CHIP	100K 5% 1/10W
R316	1-216-097-00	METAL CHIP	100K 5% 1/10W
R317	1-216-097-00	METAL CHIP	100K 5% 1/10W
R318	1-216-097-00	METAL CHIP	100K 5% 1/10W
R319	1-216-097-00	METAL CHIP	100K 5% 1/10W
R321	1-216-065-00	METAL CHIP	4.7K 5% 1/10W
R322	1-216-097-00	METAL CHIP	100K 5% 1/10W (US, Canadian, JE, SP)
R323	1-216-089-00	METAL CHIP	47K 5% 1/10W (AEP, UK)
R324	1-216-089-00	METAL CHIP	47K 5% 1/10W (US, Canadian, JE, SP)
R325	1-216-097-00	METAL CHIP	100K 5% 1/10W (AEP, UK)
R367	1-216-025-00	METAL CHIP	100 5% 1/10W
R368	1-216-025-00	METAL CHIP	100 5% 1/10W
R369	1-216-025-00	METAL CHIP	100 5% 1/10W
R370	1-216-025-00	METAL CHIP	100 5% 1/10W
R372	1-216-025-00	METAL CHIP	100 5% 1/10W
R373	1-216-025-00	METAL CHIP	100 5% 1/10W
R374	1-216-025-00	METAL CHIP	100 5% 1/10W
R376	1-249-429-11	CARBON	10K 5% 1/4W
< SWITCH >			
S301	1-692-481-11	SWITCH, KEY BOARD	(EDIT/ON)
S302	1-692-481-11	SWITCH, KEY BOARD	(◀▶)
S303	1-692-481-11	SWITCH, KEY BOARD	(ENTER/YES)
S304	1-692-481-11	SWITCH, KEY BOARD	(EJECT ▲)
S305	1-692-481-11	SWITCH, KEY BOARD	(REC ●)
S306	1-692-481-11	SWITCH, KEY BOARD	(▶▶)
S307	1-692-481-11	SWITCH, KEY BOARD	(P. MODE)
S308	1-692-481-11	SWITCH, KEY BOARD	(>   )
S309	1-692-481-11	SWITCH, KEY BOARD	(■)
S310	1-692-481-11	SWITCH, KEY BOARD	(INPUT SELECTOR)
S311	1-692-481-11	SWITCH, KEY BOARD	(DISPLAY)
S312	1-692-481-11	SWITCH, KEY BOARD	(CLOCK SET)
S313	1-692-481-11	SWITCH, KEY BOARD	(POWER)
< VIBRATOR >			
X301	1-567-098-00	OSCILLATOR, CRYSTAL	(32.768kHz)
X302	1-579-841-21	VIBRATOR, CERAMIC (CHIP TYPE)	(5MHz)

\*\*\*\*\*

Ref. No.	Part No.	Description	Remark
A-4649-454-A HEAD DRIVE BOARD, COMPLETE *****			
< CAPACITOR >			
C401	1-164-004-11	CERAMIC CHIP	0.1uF 10% 25V
C402	1-164-004-11	CERAMIC CHIP	0.1uF 10% 25V
C405	1-104-476-21	FILM	2200PF 5% 630V
C406	1-135-159-21	TANTALUM CHIP	10uF 10% 20V
C407	1-164-336-11	CERAMIC CHIP	0.33uF 25V
< CONNECTOR >			
* CN403	1-750-491-31	PIN, CONNECTOR (PC BOARD)	3P
CN404	1-750-496-21	PIN, CONNECTOR (PC BOARD)	2P
CN406	1-750-498-21	PIN, CONNECTOR (PC BOARD)	4P
< DIODE >			
D401	8-719-033-60	DIODE	F1P2STP
D402	8-719-033-60	DIODE	F1P2STP
D403	8-719-033-60	DIODE	F1P2STP
D404	8-719-033-60	DIODE	F1P2STP
D405	8-719-033-60	DIODE	F1P2STP
D406	8-719-033-60	DIODE	F1P2STP
< IC >			
IC401	8-759-244-73	IC	TC74ACT540F
IC402	8-759-243-19	IC	TC7SU04F
< TRANSISTOR >			
Q401	8-729-017-97	TRANSISTOR	ME8P06-TE16F3
Q402	8-729-017-97	TRANSISTOR	ME8P06-TE16F3
Q403	8-729-017-96	TRANSISTOR	ME6N10-TE16F3
Q404	8-729-017-96	TRANSISTOR	ME6N10-TE16F3
< RESISTOR >			
R401	1-216-097-00	METAL CHIP	100K 5% 1/10W
R402	1-216-097-00	METAL CHIP	100K 5% 1/10W
R403	1-216-097-00	METAL CHIP	100K 5% 1/10W
R404	1-216-097-00	METAL CHIP	100K 5% 1/10W
R405	1-216-298-00	METAL CHIP	2.2 5% 1/10W
R406	1-216-298-00	METAL CHIP	2.2 5% 1/10W
R426	1-216-298-00	METAL CHIP	2.2 5% 1/10W
R427	1-216-298-00	METAL CHIP	2.2 5% 1/10W
R430	1-216-073-00	METAL CHIP	10K 5% 1/10W
R431	1-216-049-00	METAL CHIP	1K 5% 1/10W
R432	1-216-049-00	METAL CHIP	1K 5% 1/10W
R433	1-216-138-00	METAL CHIP	3.3 5% 1/8W
R434	1-216-138-00	METAL CHIP	3.3 5% 1/8W
R435	1-216-138-00	METAL CHIP	3.3 5% 1/8W
R436	1-216-138-00	METAL CHIP	3.3 5% 1/8W
R437	1-216-134-00	METAL CHIP	2.2 5% 1/8W

**HEAD DRIVE** **HP** **IN/OUT SW**

**INTERRUPTER** **LOADING MOTOR** **MIC**

Ref.No.	Part No.	Description	Remark	Ref.No.	Part No.	Description	Remark
R438	1-216-134-00	METAL CHIP	2.2 5% 1/8W	*****			
R439	1-216-134-00	METAL CHIP	2.2 5% 1/8W				
R440	1-216-134-00	METAL CHIP	2.2 5% 1/8W				
R451	1-216-073-00	METAL CHIP	10K 5% 1/10W				
R452	1-216-073-00	METAL CHIP	10K 5% 1/10W				
*****				A-4649-442-A MIC BOARD, COMPLETE			
				*****			
				< CAPACITOR >			
*****				C351	1-164-004-11	CERAMIC CHIP	0.1uF 10% 25V
				C352	1-163-141-00	CERAMIC CHIP	0.001uF 5% 50V
				C353	1-163-117-00	CERAMIC CHIP	100PF 5% 50V
				C354	1-126-204-11	ELECT CHIP	47uF 20% 16V
				C355	1-164-004-11	CERAMIC CHIP	0.1uF 10% 25V
*	1-647-644-11	HP BOARD					
				*****			
				< CAPACITOR >			
C371	1-163-141-00	CERAMIC CHIP	0.001uF 5% 50V	C356	1-163-141-00	CERAMIC CHIP	0.001uF 5% 50V
C372	1-163-141-00	CERAMIC CHIP	0.001uF 5% 50V	C357	1-164-004-11	CERAMIC CHIP	0.1uF 10% 25V
C373	1-164-004-11	CERAMIC CHIP	0.1uF 10% 25V	C358	1-163-141-00	CERAMIC CHIP	0.001uF 5% 50V
				C359	1-163-141-00	CERAMIC CHIP	0.001uF 5% 50V
				C361	1-164-004-11	CERAMIC CHIP	0.1uF 10% 25V
				< CONNECTOR >			
* CN371	1-695-003-11	PIN, CONNECTOR (PC BOARD)	3P	C362	1-163-141-00	CERAMIC CHIP	0.001uF 5% 50V
				C363	1-163-117-00	CERAMIC CHIP	100PF 5% 50V
				C364	1-126-204-11	ELECT CHIP	47uF 20% 16V
				C365	1-164-004-11	CERAMIC CHIP	0.1uF 10% 25V
				C366	1-163-141-00	CERAMIC CHIP	0.001uF 5% 50V
J371	1-562-837-21	JACK (HEADPHONES)					
				< CONNECTOR >			
				< VARIABLE RESISTOR >			
RV371	1-223-249-11	RES, VAR, CARBON 1K/1K (LEVEL)		* CN351	1-695-006-11	PIN, CONNECTOR (PC BOARD)	6P
				< IC >			
*****				IC351	8-759-636-55	IC	M5218AFP
*	1-647-652-11	IN/OUT SW BOARD					
				*****			
				< JACK >			
				J351	1-562-837-21	JACK (MIC)	
				< RESISTOR >			
CN412	1-750-497-21	PIN, CONNECTOR (PC BOARD)	3P	R351	1-216-073-00	METAL CHIP	10K 5% 1/10W
				R352	1-216-081-00	METAL CHIP	22K 5% 1/10W
				R353	1-216-041-00	METAL CHIP	470 5% 1/10W
				R354	1-216-077-00	METAL CHIP	15K 5% 1/10W
				R355	1-216-097-00	METAL CHIP	100K 5% 1/10W
				R356	1-216-041-00	METAL CHIP	470 5% 1/10W
				R357	1-216-041-00	METAL CHIP	470 5% 1/10W
				R358	1-216-041-00	METAL CHIP	470 5% 1/10W
				R361	1-216-073-00	METAL CHIP	10K 5% 1/10W
				R362	1-216-081-00	METAL CHIP	22K 5% 1/10W
				R363	1-216-041-00	METAL CHIP	470 5% 1/10W
				R364	1-216-077-00	METAL CHIP	15K 5% 1/10W
				R365	1-216-097-00	METAL CHIP	100K 5% 1/10W
				R366	1-216-041-00	METAL CHIP	470 5% 1/10W
*****				*****			
				< CONNECTOR >			
CN409	1-750-496-21	PIN, CONNECTOR (PC BOARD)	2P				

Ref. No.	Part No.	Description	Remark	Ref. No.	Part No.	Description	Remark
*	1-647-645-11	REC VOL BOARD *****		C260	1-135-159-21	TANTALUM CHIP 10uF 10%	20V
		< CONNECTOR >		C261	1-164-004-11	CERAMIC CHIP 0.1uF 10%	25V
* CN381	1-695-006-31	PIN, CONNECTOR (PC BOARD) 6P		C262	1-135-159-21	TANTALUM CHIP 10uF 10%	20V
		< VARIABLE RESISTOR >		C265	1-164-004-11	CERAMIC CHIP 0.1uF 10%	25V
RV381	1-223-248-11	RES, VAR, CARBON 20K/20K (REC LEVEL)		C267	1-163-989-11	CERAMIC CHIP 0.033uF 10%	25V
*****				C268	1-126-191-11	ELECT CHIP 0.47uF 20%	50V
	A-4649-450-A	RF BOARD, COMPLETE *****		C269	1-164-004-11	CERAMIC CHIP 0.1uF 10%	25V
		< CAPACITOR >		C270	1-126-395-11	ELECT 22uF 20%	16V
C201	1-164-004-11	CERAMIC CHIP 0.1uF 10%	25V	C271	1-104-544-11	FILM CHIP 0.0027uF 5%	50V
C202	1-126-206-11	ELECT CHIP 100uF 20%	6.3V	C272	1-163-009-11	CERAMIC CHIP 0.001uF 10%	50V
C215	1-126-395-11	ELECT 22uF 20%	16V	C273	1-164-489-11	CERAMIC CHIP 0.22uF 10%	16V
C216	1-164-004-11	CERAMIC CHIP 0.1uF 10%	25V	C274	1-164-004-11	CERAMIC CHIP 0.1uF 10%	25V
C219	1-164-232-11	CERAMIC CHIP 0.01uF 50V		C280	1-164-232-11	CERAMIC CHIP 0.01uF 50V	
C220	1-126-602-11	ELECT CHIP 3.3uF 20%	50V	C281	1-164-004-11	CERAMIC CHIP 0.1uF 10%	25V
C221	1-104-640-11	FILM CHIP 0.22uF 5%	16V	C282	1-164-232-11	CERAMIC CHIP 0.01uF 50V	
C223	1-164-004-11	CERAMIC CHIP 0.01uF 50V		C284	1-164-004-11	CERAMIC CHIP 0.1uF 10%	25V
C224	1-126-206-11	ELECT CHIP 100uF 20%	6.3V	C285	1-164-004-11	CERAMIC CHIP 0.1uF 10%	25V
C225	1-104-557-11	FILM CHIP 0.033uF 5%	16V	C286	1-164-004-11	CERAMIC CHIP 0.1uF 10%	25V
C226	1-126-191-11	ELECT CHIP 0.47uF 20%	50V	C287	1-164-004-11	CERAMIC CHIP 0.1uF 10%	25V
C227	1-126-395-11	ELECT 22uF 20%	16V	C288	1-163-009-11	CERAMIC CHIP 0.001uF 10%	50V
C228	1-164-004-11	CERAMIC CHIP 0.1uF 10%	25V	C294	1-164-004-11	CERAMIC CHIP 0.1uF 10%	25V
C229	1-126-395-11	ELECT 22uF 20%	16V	C295	1-164-489-11	CERAMIC CHIP 0.22uF 10%	16V
C230	1-137-286-11	FILM CHIP 0.0022uF 5%	16V	C296	1-164-489-11	CERAMIC CHIP 0.22uF 10%	16V
C231	1-104-563-11	FILM CHIP 0.1uF 5%	16V	< CONNECTOR >			
C232	1-104-559-11	FILM CHIP 0.047uF 5%	16V	CN201	1-580-888-11	SOCKET, CONNECTOR (SMT) 18P	
C233	1-126-395-11	ELECT 22uF 20%	16V	CN202	1-580-876-11	SOCKET, CONNECTOR (SMT) 5P	
C234	1-104-563-11	FILM CHIP 0.1uF 5%	16V	* CN203	1-695-241-31	PIN, CONNECTOR (PC BOARD) 8P	
C240	1-164-004-11	CERAMIC CHIP 0.1uF 10%	25V	* CN205	1-750-491-31	PIN, CONNECTOR (PC BOARD) 3P	
C241	1-164-004-11	CERAMIC CHIP 0.1uF 10%	25V	* CN206	1-750-494-11	PIN, CONNECTOR (PC BOARD) 6P	
C242	1-126-191-11	ELECT CHIP 0.47uF 20%	50V	* CN207	1-750-279-11	CONNECTOR, FFC/FPC 24P	
C243	1-163-139-00	CERAMIC CHIP 820PF 5%	50V	* CN208	1-750-279-11	CONNECTOR, FFC/FPC 24P	
C244	1-163-121-00	CERAMIC CHIP 150PF 5%	50V	* CN210	1-695-241-31	PIN, CONNECTOR (PC BOARD) 8P	
C245	1-163-121-00	CERAMIC CHIP 150PF 5%	50V	* CN211	1-750-490-31	PIN, CONNECTOR (PC BOARD) 2P	
C250	1-126-395-11	ELECT 22uF 20%	16V	* CN212	1-750-491-31	PIN, CONNECTOR (PC BOARD) 3P	
C251	1-164-232-11	CERAMIC CHIP 0.01uF 50V		< DIODE >			
C252	1-163-037-11	CERAMIC CHIP 0.022uF 10%	25V	D202	8-719-029-88	DIODE HSM198STL	
C253	1-163-009-11	CERAMIC CHIP 0.001uF 10%	50V	D203	8-719-016-74	DIODE 1SS352	
C254	1-163-037-11	CERAMIC CHIP 0.022uF 10%	25V	D204	8-719-017-76	DIODE MA8030	
C255	1-163-018-00	CERAMIC CHIP 0.0056uF 5%	50V	D205	8-719-977-03	DIODE DTZ5.6B	
C256	1-163-009-11	CERAMIC CHIP 0.001uF 10%	50V	< IC >			
C257	1-104-555-11	FILM CHIP 0.022uF 5%	16V	IC205	8-752-057-45	IC CXA1082BQ	
C258	1-164-004-11	CERAMIC CHIP 0.1uF 10%	25V	IC206	8-759-981-48	IC RC082M2G2	
C259	1-126-193-11	ELECT 1uF 20%	50V	IC207	8-759-009-06	IC MC14052BF	
				IC208	8-759-745-64	IC NJM4560M	
				IC209	8-752-064-34	IC CXA1381R	
				IC213	8-759-242-70	IC TC7WU04F	
				IC214	8-759-300-71	IC HD14053BFP	
				IC215	8-759-300-71	IC HD14053BFP	

Ref. No.	Part No.	Description	Remark	Ref. No.	Part No.	Description	Remark
IC216	8-759-242-64	IC TC4W53F		R241	1-216-691-11	METAL CHIP 47K 0.5% 1/10W	
	< COIL >			R242	1-216-121-00	METAL CHIP 1M 5% 1/10W	
L201	1-543-948-11	BEAD, FERRITE (CHIP)		R243	1-216-675-11	METAL CHIP 10K 0.5% 1/10W	
L202	1-543-948-11	BEAD, FERRITE (CHIP)		R244	1-218-766-11	METAL CHIP 390K 0.5% 1/10W	
L203	1-543-948-11	BEAD, FERRITE (CHIP)		R245	1-216-081-00	METAL CHIP 22K 5% 1/10W	
L204	1-543-948-11	BEAD, FERRITE (CHIP)		R246	1-216-667-11	METAL CHIP 4.7K 0.5% 1/10W	
	< TRANSISTOR >			R247	1-216-668-11	METAL CHIP 5.1K 0.5% 1/10W	
Q201	8-729-901-06	TRANSISTOR DTA144EK		R248	1-216-049-00	METAL CHIP 1K 5% 1/10W	
Q202	8-729-620-06	TRANSISTOR 2SC3052-EF		R249	1-216-028-00	METAL CHIP 130 5% 1/10W	
Q203	8-729-101-07	TRANSISTOR 2SB798-DL		R250	1-216-081-00	METAL CHIP 22K 5% 1/10W	
Q204	8-729-421-19	TRANSISTOR UN2213		R252	1-216-093-00	METAL CHIP 68K 5% 1/10W	
Q205	8-729-901-06	TRANSISTOR DTA144EK		R253	1-216-093-00	METAL CHIP 68K 5% 1/10W	
Q209	8-729-620-06	TRANSISTOR 2SC3052-EF		R254	1-216-699-11	METAL CHIP 100K 0.5% 1/10W	
Q210	8-729-421-19	TRANSISTOR UN2213		R255	1-216-668-11	METAL CHIP 5.1K 0.5% 1/10W	
	< RESISTOR >			R256	1-216-093-00	METAL CHIP 68K 5% 1/10W	
R111	1-216-295-00	METAL CHIP 0 5% 1/10W		R257	1-216-057-00	METAL CHIP 2.2K 5% 1/10W	
R112	1-216-295-00	METAL CHIP 0 5% 1/10W		R258	1-216-057-00	METAL CHIP 2.2K 5% 1/10W	
R201	1-216-057-00	METAL CHIP 2.2K 5% 1/10W		R259	1-216-049-00	METAL CHIP 1K 5% 1/10W	
R203	1-218-754-11	METAL CHIP 120K 0.5% 1/10W		R260	1-216-047-00	METAL CHIP 820 5% 1/10W	
R211	1-216-085-00	METAL CHIP 33K 5% 1/10W		R261	1-218-281-11	METAL CHIP 18 5% 1/2W	
R212	1-216-085-00	METAL CHIP 33K 5% 1/10W		R262	1-216-097-00	METAL CHIP 100K 5% 1/10W	
R213	1-216-085-00	METAL CHIP 33K 5% 1/10W		R263	1-216-045-00	METAL CHIP 680 5% 1/10W	
R214	1-216-085-00	METAL CHIP 33K 5% 1/10W		R264	1-216-057-00	METAL CHIP 2.2K 5% 1/10W	
R215	1-216-085-00	METAL CHIP 33K 5% 1/10W		R265	1-216-081-00	METAL CHIP 22K 5% 1/10W	
R216	1-216-085-00	METAL CHIP 33K 5% 1/10W		R266	1-216-065-00	METAL CHIP 4.7K 5% 1/10W	
R217	1-216-069-00	METAL CHIP 6.8K 5% 1/10W		R267	1-216-692-11	METAL CHIP 51K 0.5% 1/10W	
R218	1-216-069-00	METAL CHIP 6.8K 5% 1/10W		R268	1-218-772-11	METAL CHIP 680K 0.5% 1/10W	
R219	1-216-085-00	METAL CHIP 33K 5% 1/10W		R270	1-216-049-00	METAL CHIP 1K 5% 1/10W	
R220	1-216-085-00	METAL CHIP 33K 5% 1/10W		R271	1-216-121-00	METAL CHIP 1M 5% 1/10W	
R221	1-216-085-00	METAL CHIP 33K 5% 1/10W		R272	1-216-065-00	METAL CHIP 4.7K 5% 1/10W	
R222	1-216-085-00	METAL CHIP 33K 5% 1/10W		R273	1-216-049-00	METAL CHIP 1K 5% 1/10W	
R223	1-216-660-11	METAL CHIP 2.4K 0.5% 1/10W		R274	1-216-121-00	METAL CHIP 1M 5% 1/10W	
R224	1-216-081-00	METAL CHIP 22K 5% 1/10W		R275	1-216-044-00	METAL CHIP 620 5% 1/10W	
R225	1-216-069-00	METAL CHIP 6.8K 5% 1/10W		R276	1-216-097-00	METAL CHIP 100K 5% 1/10W	
R226	1-216-069-00	METAL CHIP 6.8K 5% 1/10W		R277	1-216-697-11	METAL CHIP 82K 0.5% 1/10W	
R227	1-216-662-11	METAL CHIP 3K 0.5% 1/10W		R278	1-216-073-00	METAL CHIP 10K 5% 1/10W	
R228	1-216-049-00	METAL CHIP 1K 5% 1/10W		R279	1-216-049-00	METAL CHIP 1K 5% 1/10W	
R229	1-216-699-11	METAL CHIP 100K 0.5% 1/10W		R280	1-216-667-11	METAL CHIP 4.7K 0.5% 1/10W	
R230	1-216-661-11	METAL CHIP 2.7K 0.5% 1/10W		R281	1-216-668-11	METAL CHIP 5.1K 0.5% 1/10W	
R231	1-216-097-00	METAL CHIP 100K 5% 1/10W		R282	1-216-659-11	METAL CHIP 2.2K 0.5% 1/10W	
R232	1-216-699-11	METAL CHIP 100K 0.5% 1/10W		R283	1-216-073-00	METAL CHIP 10K 5% 1/10W	
R233	1-216-697-11	METAL CHIP 82K 0.5% 1/10W		R284	1-216-097-00	METAL CHIP 100K 5% 1/10W	
R234	1-216-691-11	METAL CHIP 47K 0.5% 1/10W		R285	1-216-049-00	METAL CHIP 1K 5% 1/10W	
R235	1-216-695-11	METAL CHIP 68K 0.5% 1/10W		R286	1-216-073-00	METAL CHIP 10K 5% 1/10W	
R236	1-216-681-11	METAL CHIP 18K 0.5% 1/10W		R287	1-216-049-00	METAL CHIP 1K 5% 1/10W	
R237	1-218-769-11	METAL CHIP 510K 0.5% 1/10W		R288	1-216-073-00	METAL CHIP 10K 5% 1/10W	
R240	1-218-754-11	METAL CHIP 120K 0.5% 1/10W		R289	1-216-073-00	METAL CHIP 10K 5% 1/10W	
				R290	1-216-073-00	METAL CHIP 10K 5% 1/10W	
				R291	1-216-065-00	METAL CHIP 4.7K 5% 1/10W	
				R292	1-216-081-00	METAL CHIP 22K 5% 1/10W	



**RF SERVO DRIVE**

Ref. No.	Part No.	Description	Remark
R293	1-216-049-00	METAL CHIP 1K 5% 1/10W	
R294	1-216-092-00	METAL CHIP 62K 5% 1/10W	
R295	1-216-021-00	METAL CHIP 68 5% 1/10W	
R296	1-216-057-00	METAL CHIP 2.2K 5% 1/10W	
R297	1-218-236-91	METAL CHIP 1 10% 1/4W	
R298	1-216-679-11	METAL CHIP 15K 0.5% 1/10W	
R299	1-216-674-11	METAL CHIP 9.1K 0.5% 1/10W	
< VARIABLE RESISTOR >			
RV201	1-241-396-11	RES, ADJ, METAL GLAZE 22K	
RV202	1-241-396-11	RES, ADJ, METAL GLAZE 22K	
RV203	1-241-396-11	RES, ADJ, METAL GLAZE 22K	
RV204	1-241-392-11	RES, ADJ, METAL GLAZE 1K	
RV205	1-241-393-21	RES, ADJ, METAL GLAZE 2.2K	
RV206	1-241-394-11	RES, ADJ, METAL GLAZE 4.7K	
RV207	1-241-396-11	RES, ADJ, METAL GLAZE 22K	
RV208	1-241-396-11	RES, ADJ, METAL GLAZE 22K	
RV209	1-241-394-11	RES, ADJ, METAL GLAZE 4.7K	
RV210	1-241-396-11	RES, ADJ, METAL GLAZE 22K	
RV211	1-241-396-11	RES, ADJ, METAL GLAZE 22K	
RV212	1-241-394-11	RES, ADJ, METAL GLAZE 4.7K	
RV215	1-241-394-11	RES, ADJ, METAL GLAZE 4.7K	
*****			
A-4649-658-A SERVO DRIVE BOARD, COMPLETE			
*****			
*	4-875-327-01	HEAT SINK	
*	4-922-525-01	HEAT SINK	
	7-685-871-01	SCREW +BVTT 3X6 (S)	
< CAPACITOR >			
C408	1-164-004-11	CERAMIC CHIP 0.1uF 10% 25V	
C409	1-164-004-11	CERAMIC CHIP 0.1uF 10% 25V	
C410	1-164-004-11	CERAMIC CHIP 0.1uF 10% 25V	
C411	1-126-204-11	ELECT CHIP 47uF 20% 16V	
C412	1-126-204-11	ELECT CHIP 47uF 20% 16V	
C413	1-126-204-11	ELECT CHIP 47uF 20% 16V	
C414	1-126-204-11	ELECT CHIP 47uF 20% 16V	
C415	1-164-004-11	CERAMIC CHIP 0.1uF 10% 25V	
C416	1-164-004-11	CERAMIC CHIP 0.1uF 10% 25V	
C417	1-164-004-11	CERAMIC CHIP 0.1uF 10% 25V	
C418	1-126-206-11	ELECT CHIP 100uF 20% 6.3V	
C419	1-164-004-11	CERAMIC CHIP 0.1uF 10% 25V	
C420	1-126-206-11	ELECT CHIP 100uF 20% 6.3V	
C421	1-164-004-11	CERAMIC CHIP 0.1uF 10% 25V	
C422	1-126-206-11	ELECT CHIP 100uF 20% 6.3V	
< CONNECTOR >			
* CN401	1-695-008-11	PIN, CONNECTOR (PC BOARD) 8P	
* CN402	1-750-490-31	PIN, CONNECTOR (PC BOARD) 2P	

Ref. No.	Part No.	Description	Remark
* CN405	1-695-241-31	PIN, CONNECTOR (PC BOARD) 8P	
* CN407	1-750-491-31	PIN, CONNECTOR (PC BOARD) 3P	
* CN408	1-750-494-11	PIN, CONNECTOR (PC BOARD) 6P	
< IC >			
IC404	8-759-823-11	IC LA6523	
IC405	8-759-823-11	IC LA6523	
IC406	8-759-089-53	IC uPC79M05HF	
IC407	8-759-144-82	IC uPC2405HF	
IC408	8-759-144-82	IC uPC2405HF	
< RESISTOR >			
R407	1-216-001-00	METAL CHIP 10 5% 1/10W	
R408	1-216-001-00	METAL CHIP 10 5% 1/10W	
R409	1-216-001-00	METAL CHIP 10 5% 1/10W	
R410	1-216-073-00	METAL CHIP 10K 5% 1/10W	
R411	1-216-073-00	METAL CHIP 10K 5% 1/10W	
R412	1-216-687-11	METAL CHIP 33K 0.5% 1/10W	
R413	1-216-691-11	METAL CHIP 47K 0.5% 1/10W	
R414	1-216-093-00	METAL CHIP 68K 5% 1/10W	
R415	1-216-687-11	METAL CHIP 33K 0.5% 1/10W	
R416	1-216-001-00	METAL CHIP 10 5% 1/10W	
R417	1-216-001-00	METAL CHIP 10 5% 1/10W	
R418	1-216-073-00	METAL CHIP 10K 5% 1/10W	
R419	1-216-073-00	METAL CHIP 10K 5% 1/10W	
R420	1-216-687-11	METAL CHIP 33K 0.5% 1/10W	
R421	1-216-687-11	METAL CHIP 33K 0.5% 1/10W	
R453	1-216-295-00	METAL CHIP 0 5% 1/10W	
R454	1-216-295-00	METAL CHIP 0 5% 1/10W	
R456	1-216-295-00	METAL CHIP 0 5% 1/10W	
*****			
MISCELLANEOUS			
*****			
△60	1-558-945-21	CORD, POWER (POLAR. SPT-1) (US, Canadian)	
△60	1-696-027-11	CORD, POWER (JE)	
△63	1-696-586-21	CORD, POWER (UK)	
△64	1-751-275-11	CORD, POWER (AEP, SP)	
68	1-500-051-11	BEAD, FERRITE (WITH CASE)	
121	1-751-068-11	WIRE (FLAT TYPE) (24 CORE)	
△214	8-583-003-21	DEVICE, MINIATURE DISK KMS-140B	
220	1-500-006-11	HEAD, OVER WRITE	
M401	A-4660-373-A	MOTOR ASSY (LOADING)	
M901	X-4944-046-1	MOTOR ASSY, SLED	
△T901	1-423-398-11	TRANSFORMER, POWER (US, Canadian)	
△T901	1-423-399-11	TRANSFORMER, POWER (AEP)	
△T901	1-423-400-11	TRANSFORMER, POWER (UK)	
△T901	1-423-401-11	TRANSFORMER, POWER (JE, SP)	
*****			

<p>The components identified by mark △ or dotted line with mark △ are critical for safety. Replace only with part number specified.</p>	<p>Les composants identifiés par une marque △ sont critiques pour la sécurité. Ne les remplacer que par une pièce portant le numéro spécifié.</p>
---	---

<u>Ref. No.</u>	<u>Part No.</u>	<u>Description</u>	<u>Remark</u>
		ACCESSORIES & PACKING MATERIALS *****	
	1-466-914-11	COMMANDER, STANDARD (RM-D1M)	
	1-558-271-11	CORD, CONNECTION (PIN-JACK)	
	1-569-007-11	ADAPTER, CONVERSION 2P (JE)	
	1-569-008-11	ADAPTER, CONVERSION 2P (SP)	
	1-574-264-11	CORD, LIGHT PLUG (AEP, UK)	
	1-574-314-11	CORD (WITH CONNECTOR) (AU BUS)	
	1-690-863-11	CORD, OPTICAL (SP)	
	3-707-584-21	COVER, BATTERY (for RM-D1M)	
	3-756-535-11	MANUAL, INSTRUCTION (English, French, Spanish, Portuguese) (AEP, UK)	
	3-756-535-21	MANUAL, INSTRUCTION (English) (US, Canadian)	
	3-756-535-31	MANUAL, INSTRUCTION (French) (Canadian)	
	3-756-535-41	MANUAL, INSTRUCTION (German, Dutch, Swedish, Italian) (AEP)	
	3-756-535-51	MANUAL, INSTRUCTION (English, Korean, Chinese) (JE)	
	3-756-535-61	MANUAL, INSTRUCTION (English, French, Spanish, Chinese) (SP)	
*	4-957-256-11	INDIVIDUAL CARTON (US, Canadian, AEP, JE)	
*	4-957-651-01	CUSHION (UPPER)	
*	4-957-652-01	CUSHION (LOWER)	
*	4-959-653-01	INDIVIDUAL CARTON (UK, SP)	
		*****	
		***** HARDWARE LIST *****	
#1	7-682-547-09	SCREW +BVTT 3X6 (S)	
#2	7-685-646-79	SCREW +BVTP 3X8 TYPE2 N-S	
#3	7-682-548-09	SCREW +BVTT 3X8 (S)	
#4	7-621-775-10	SCREW +B 2.6X4	
#5	7-621-770-XX	SCREW +BVTT 2.6X8 (S)	
#6	7-621-775-00	SCREW +B 2.6X3	
#7	7-682-547-04	SCREW +B 3X6	
#8	7-621-592-00	SCREW +K 2.6X6	
#9	7-621-772-10	SCREW +B 2X4	
#10	7-627-852-08	SCREW, PRECISION +P 1.7X2.5	
#11	7-627-551-28	SCREW, PRECISION +P 1.4X2.5	
#12	7-627-552-78	SCREW, PRECISION +P 1.7X3.5	
#13	7-627-852-97	SCREW, PRECISION +P 1.7X4.5TYPE3	
#14	7-627-552-48	SCREW, PRECISION +P 1.7X4	
#15	7-627-852-38	SCREW, PRECISION +P 1.7X1.8TYPE3	
#16	7-621-255-35	SCREW (2MMX5), + PWH	
#17	7-685-871-01	SCREW +BVTT 3X6 (S)	
#18	7-621-770-67	SCREW +BVTT 2.6X6 (S)	

# SECTION 7 TEST MODE

## 7-1. TEST MODE SETTING

While pressing the P.MODE key and ▷ (PLAY) key, connect the power cord to the AC outlet, then release the P.MODE key and ▷ (PLAY) key.

## 7-2. TEST MODE RELEASING

Disconnect the power cord from the AC outlet.

## 7-3. TEST MODE OPERATION

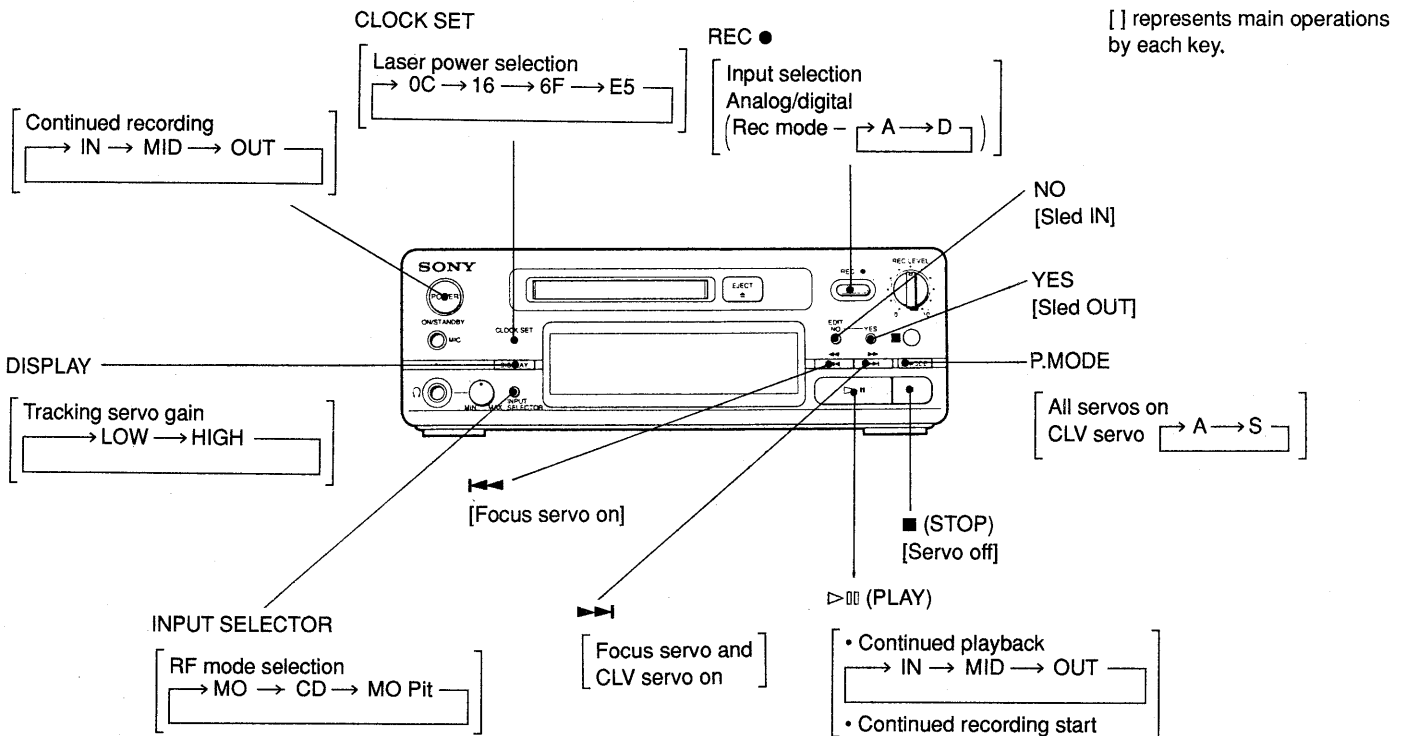

Fig. 7-1. Key arrangement

Key	Indication	Contents	Remarks	
POWER	CREC-IN	Continued recording on inner circumference	<ul style="list-style-type: none"> <li>• Indication changes as key is pressed.</li> <li>• After the indication shown in the left has appeared, repeated recording occurs at the indicated position by pressing ▷ key.</li> <li>• To stop recording, press ■ key.</li> </ul>	
	CREC-MIDDLE	Continued recording on middle circumference		
	CREC-OUT	Continued recording on outer circumference		
CLOCK SET	Laser Power 0C	CD reading power	<ul style="list-style-type: none"> <li>• Indication changes as key is pressed, laser power is switched and laser is emitted.</li> <li>• To stop the laser emission, press ■ key.</li> </ul>	
	Laser Power 16	MO reading power		
	Laser Power 6F	Laser power adjustment (3.5mV)		
	Laser Power E5	MO writing power (maximum generating power)		
DISPLAY	Trk Gain Hi	Tracking servo gain UP	<ul style="list-style-type: none"> <li>• Indication changes as key is pressed, and the tracking servo gain is selected.</li> <li>• Normally low.</li> </ul>	
	Trk Gain Low	Tracking servo gain NORMAL		
INPUT SELECTOR	RF mod=MO	RF mode : MO groove	Adjusted on the MO disc groove.	<ul style="list-style-type: none"> <li>• Indication changes as key is pressed, and the RF mode is selected.</li> </ul>
	RF mod=CD	RF mode : CD	Adjusted on the CD disc.	
	RF mod=MO Pit	RF mode : MO pit	Adjusted on the MO disc pit.	
EJECT	OPEN	Disc ejection		
	CLOSE	Disc loading		
REC ■	Red mode-A	Operation mode of CXD2525R : analog	PLL master mode	<ul style="list-style-type: none"> <li>• Indication changes as key is pressed, and the input is selected. (analog/digital)</li> </ul>
	Red mode-D	Operation mode of CXD2525R : digital	PLL slave mode	
EDIT NO	Sled in	Sled is moved toward inner circumference.	<ul style="list-style-type: none"> <li>• Sled moves during key is pressed, and stops when key is released.</li> </ul>	
YES	Sled out	Sled is moved toward outer circumference.		
◀◀	Fcs on	Focus servo on	<ul style="list-style-type: none"> <li>• Only focus servo is on by pressing key.</li> </ul>	
▶▶	Fcs ClvS on	Focus / spindle (S) servo on	<ul style="list-style-type: none"> <li>• Focus servo and spindle servo (S) are on by pressing key.</li> </ul>	
P.MODE	Fcs ClvA Tr on	Focus / spindle (A) / tracking servo on	<ul style="list-style-type: none"> <li>• Indication changes as key is pressed, and each servo is on.</li> </ul>	
	Fcs ClvS Tr on	Focus / spindle (S) / tracking servo on		
▷ (PLAY)	C PLAY-IN	Continued playback of inner circumference	<ul style="list-style-type: none"> <li>• Indication changes as key is pressed, repeated recording occurs at the indicated position.</li> <li>• To stop the playback, press ■ key.</li> </ul>	
	C PLAY-MID	Continued playback of middle circumference		
	C PLAY-OUT	Continued playback of outer circumference		
■ (STOP)	—	All servos off		

Table 7-1. Test mode operation

## SECTION 8 ELECTRICAL ADJUSTMENTS

### 8-1. CAUTION ON LASER DIODE EMITTING CONFIRMATION

Never look the laser diode emission from right above when adjusting. It may cause loss of eyesight.

### 8-2. NOTE ON MiniDisc DEVICE (KMS-140B) HANDLING

The laser diode within the optical pickup is extremely subjected to electrostatic destruction. So, the laser tap on the flexible board should be bridge soldering when handling. Furthermore, take fully measurements against the electrostatic destruction. Take care of handling the flexible board because it can be damaged.

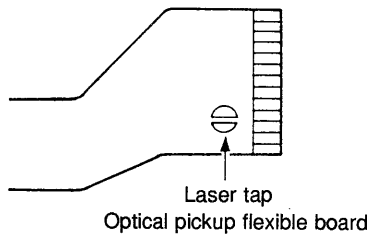

After replacing the MiniDisc device, perform adjustment and confirmation as follows.

- Temperature compensation offset adjustment
- Laser power adjustment
- MO groove traverse adjustment
- E-F balance adjustment
- MO pit traverse adjustment
- CD RF level adjustment
- CD traverse adjustment
- Error rate confirmation

### 8-3. NOTE ON ADJUSTMENT

- 1) Perform adjustment in the test mode.  
Release the test mode after adjustment.
- 2) Adjustment should be performed in order described.
- 3) Use jigs and measurement tools described below.
  - CD test disc TGYS-1 (Part No.: 4-959-188-01)
  - Continued recorded disc PTDM-1 (Part No.: J-2501-054-A)
  - Laser power meter LPM-8001 (Part No.: J-2501-046-A)
  - Error rate counter MDPE-1 (Part No.: J-2501-047-A)
  - Oscilloscope (band more than 40 MΩ, Calibrate the probe before performing the measurement.)
  - Digital volt meter
  - Temperature meter

### 8-4. OFFSET ADJUSTMENT

Note: This adjustment should be performed immediately after setting the test mode. Performing other adjustments switch the operation mode, and the correct adjustment can not be performed.

#### 1) Temperature compensation offset adjustment

Connection:

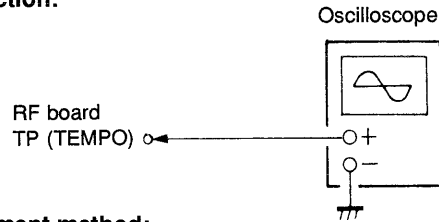

Adjustment method:

1. Connect the oscilloscope to TP (TEMPO) on the RF board.
2. Adjust RV205 on the RF board so that the reading on the oscilloscope meets the specification.

Specification:  $0 \pm 50\text{mV}$  (25°C)  
 $+27\text{mV}/^\circ\text{C}$  (Increased by 27mV with every increasing temperature by 1°C)

#### 2) Focus bias offset adjustment

Connection:

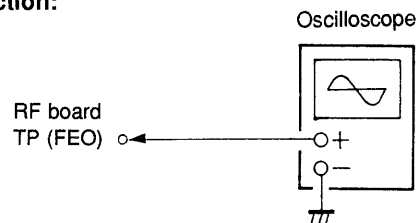

Adjustment method:

1. Connect the oscilloscope to TP (FEO) on the RF board.
2. Adjust RV208 on the RF board so that the reading on the oscilloscope becomes  $0 \pm 20\text{mV}$ .

#### 3) FOK offset adjustment

Connection:

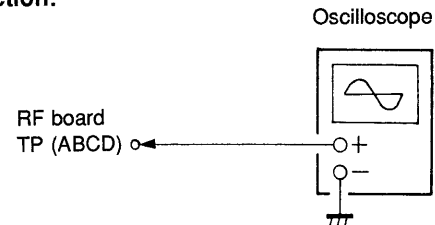

Adjustment method:

1. Connect the oscilloscope to TP (ABCD) (IC209<sup>Ⓢ</sup>) on the RF board.
2. Adjust RV207 on the RF board so that the reading on the oscilloscope becomes  $0 \pm 20\text{mV}$ .

## 8-5. LASER POWER ADJUSTMENT

### Connection:

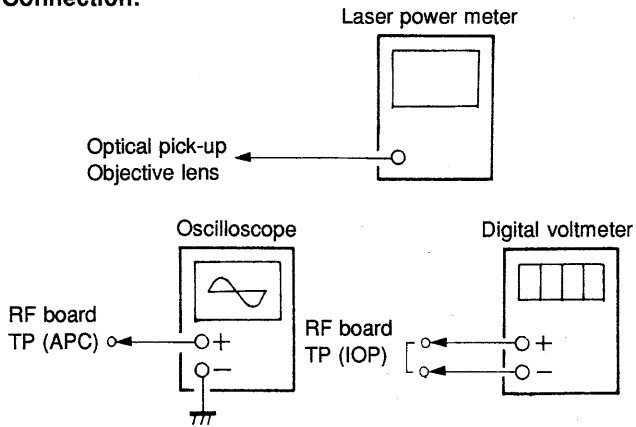

### Adjustment method:

1. Place the laser power meter on the objective lens of the optical pick-up. (If setting can not be made correctly, move the sled using the YES or NO key.)  
Connect the oscilloscope to TP (APC) on the RF board, the digital voltmeter to TP (IOP) respectively.
2. Press the CLOCK SET key to let "Laser Power 6F" appear. (laser power : for adjustment)
3. Adjust RV204 on the RF board so that the reading on the laser power meter becomes  $3.6 \pm 0.1 \text{ mW}$ .  
At this time, confirm that the reading on the oscilloscope is  $1.5 \pm 0.1 \text{ V}$ .
4. Press the CLOCK SET key to let "Laser Power E5" appear. (laser power : MO writing)
5. At this time, confirm that the reading on the laser power meter, oscilloscope and digital voltmeter meet the specifications shown below.

#### Specifications:

Laser power meter :  $7.0^{+0}_{-0.4} \text{ mW}$   
 Oscilloscope:  $3.0 \pm 0.1 \text{ V}$   
 Digital voltmeter: Optical pickup reading  $\pm 5 \text{ mA}$

(Optical pickup level)

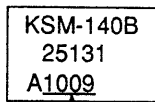

In this case :  $I_{op} = 100.9 \text{ mA}$   
 $I_{op} (\text{mA}) = \text{Digital voltmeter reading (mV)} / 1(\Omega)$

6. Press the CLOCK SET key to let "Laser Power 16" appear. (laser power : MO reading)
7. At this time, confirm that the reading on the laser power meter and oscilloscope become the specifications shown below.

#### Specifications:

Laser power meter :  $0.85 \pm 0.04 \text{ mW}$   
 Oscilloscope :  $0.37 \pm 0.1 \text{ V}$

8. Press ■ (STOP) key to stop the laser emitting.

## 8-6. MO TRAVERSE ADJUSTMENT

### Connection:

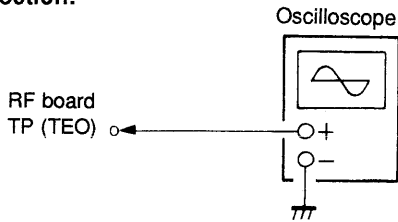

### Adjustment method:

1. Connect the Oscilloscope to TP (TEO) on the RF board.
2. Insert a MO disc (standard product).
3. Press the INPUT SELECTOR key to let "RF mod=MO" appear. (RF mode : MO groove)
4. Move the sled from pit to outer circumference by pressing the NO or YES key.
5. Press  $\blacktriangleright$  key. (Focus / spindle (S) servo on, tracking servo off)
6. Adjust the RV201 on the RF board so that the waveform of the oscilloscope meets the specification. (MO groove traverse adjustment)

(Traverse waveform)

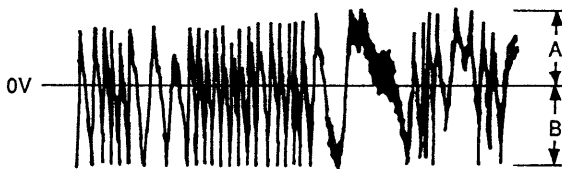

Specification: A=B

7. Press the CLOCK SET key to let "Laser Power E5" appear. (laser power : MO writing)
8. Adjust the RV209 on the RF board so that the waveform of the oscilloscope meets the specification. (E-F balance adjustment)

(Traverse waveform)

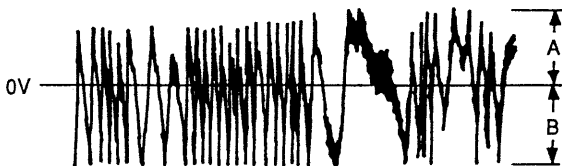

Specification: A=B

9. Press the CLOCK SET key to let "Laser Power 16" and "Laser Power E5" appear alternatively, and repeat adjustment until both offset values meet the specifications.
10. Press  $\blacksquare$  (STOP) key.
11. Move the sled to the pit portion (inner most circumference) by pressing the NO key.
12. Press the INPUT SELECTOR key to let "RF mod=MO pit" appear. (RF mode : MO Pit)
13. Press  $\blacktriangleright$  key. (Focus / spindle (S) servo on, tracking servo off)
14. Adjust the RV202 on the RF board so that the waveform of the oscilloscope meets the specification. (MO pit traverse adjustment)

(Traverse waveform)

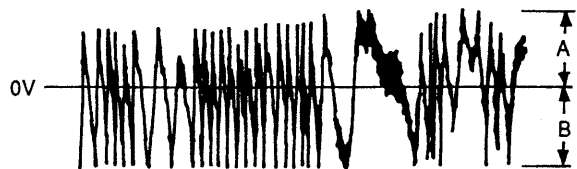

Specification: A=B

15. Press  $\blacksquare$  (STOP) key.
16. Press the EJECT key to take out the MO disc.

Note 1: If a recorded disc is used for this adjustment, the data is erased when MO writing.

Note 2: If it is hard to observe the traverse waveform, connect the oscilloscope as shown below. The appearance is improved.

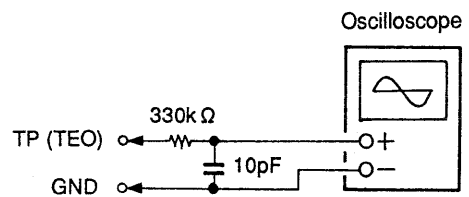

## 8-7. CD RF LEVEL ADJUSTMENT

### Condition:

Perform adjustment in the condition where the unit is in horizontal.

### Connection:

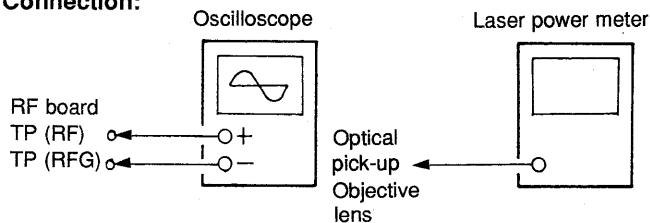

### Adjustment method:

1. Connect the Oscilloscope to TP (RF) and TP (RFG) on the RF board.
2. Insert the test disc TGYS-1.
3. Press the INPUT SELECTOR key to let "RF mod=CD" appear. (RF mode : CD)
4. Press ▷◻ (PLAY) key to perform repeated playback.
5. Adjust the RV215 on the RF board so that the RF level of the oscilloscope becomes  $1.1 \pm 0.1V_{p-p}$ .

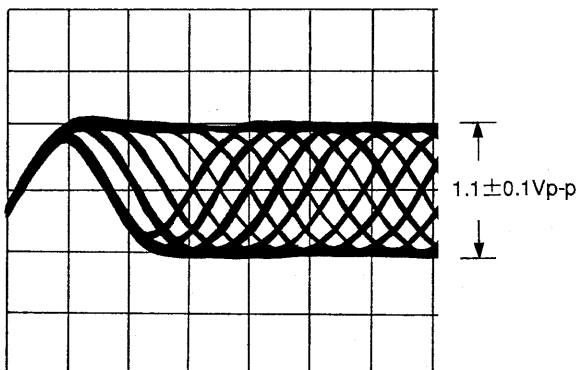

6. Press ■ (STOP) key to stop playback.
7. Press the EJECT key to take out the test disc.
8. Place the laser power meter on the objective lens of the optical pickup. (If setting can not be made correctly, move the sled using the YES or NO key.)
9. Press the CLOCK SET key to let "Laser Power 0C" appear. (laser power : CD reading)
10. Confirm that the reading of the laser power meter is  $0.49 \pm 0.06mW$ .
11. Press ■ (STOP) key to stop laser diode emitting.

## 8-8. CD TRAVERSE ADJUSTMENT

### Connection:

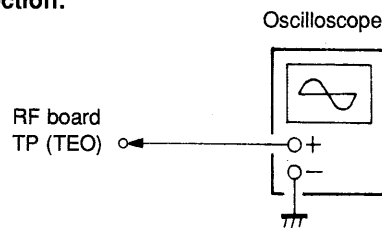

### Adjustment method:

1. Connect the Oscilloscope to TP (TEO) on the RF board.
2. Insert the test disc TGYS-1.
3. Press the INPUT SELECTOR key to let "RF mod=CD" appear. (RF mode : CD)
4. Press ►► key. (Focus / spindle (S) servo on, tracking servo off)
5. Adjust the RV203 on RF board so that the reading on the oscilloscope meets the specification.

(Traverse waveform)

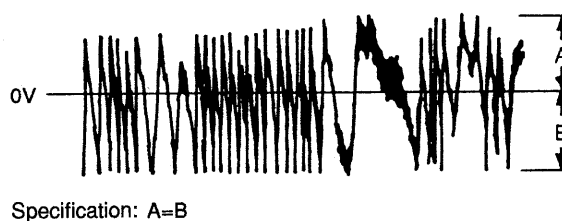

6. Press ■ (STOP) key.
7. Press the EJECT key to take out the test disc.



## 8-9. MO FOCUS BIAS ADJUSTMENT

### Connection:

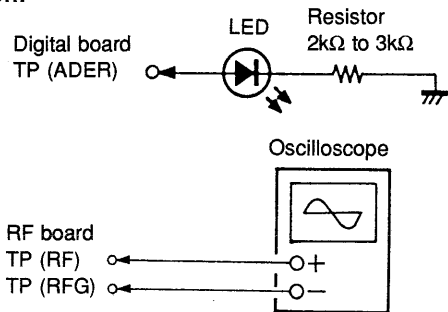

### Adjustment method:

1. Connect the LED and resistor (2 to 3kΩ) to TP (ADER) on the digital board.
2. Connect the Oscilloscope to TP (RF) and TP (RFG) on the RF board.
3. Insert the continued recorded disc PTDM-1.
4. Press the INPUT SELECTOR key to let "RF mod=MO" appear. (RF mode : MO groove)
5. Press ▷ (PLAY) key to let "C PLAY-MID" appear. (middle circumference repeated playback)  
 (Performing adjustment about two minutes after ▷ (PLAY) key is pressed allows more accurately adjustment since the adjustment is performed at the continued recording portion.)
6. Adjust the RV206 on the RF board so that the eye-pattern of the oscilloscope correctly appears. (rough adjustment)  
 (The correct eye-pattern means that ◇ shape can be identified clearly at the center of waveform.)
7. While monitoring the LED connected to the digital board and the RF waveform of the oscilloscope, adjust the RV206 so that "AD error best point" is obtained. (fine adjustment)  
 (The "AD error best point" is a point where the RF waveform does not deteriorate and the LED connected to the digital board does not light up or lights up once a ten seconds by turning the RV206 from the point where the LED lights up to pass the best point a little.)
8. Press ■ (STOP) key to stop the playback.
9. Press the EJECT key to take out the continued recorded disc.

Normally, a relation between the RF waveform and AD error is as follows.

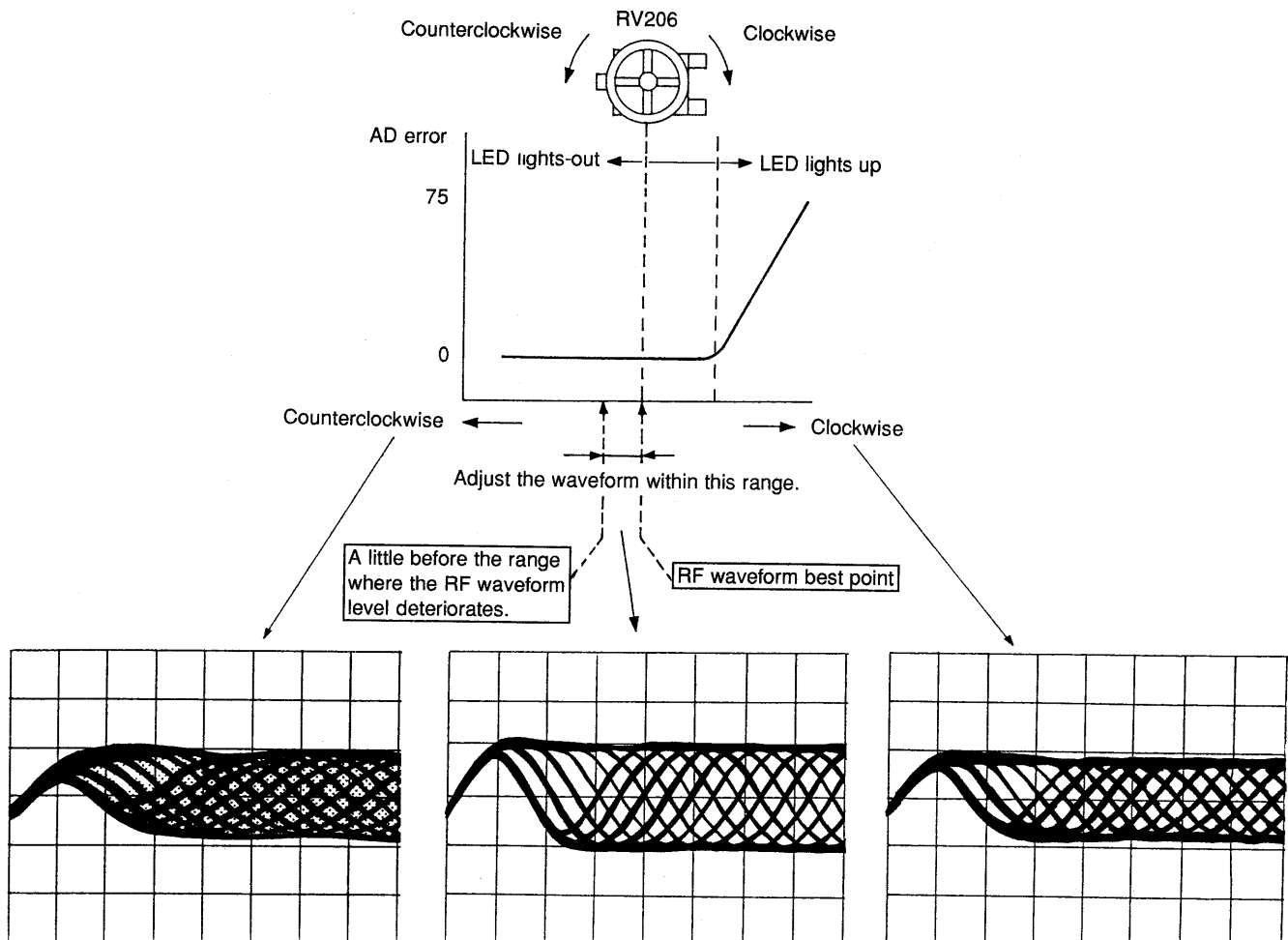

## 8-10. CD FOCUS BIAS ADJUSTMENT

### Method requiring no error rate counter

#### Connection:

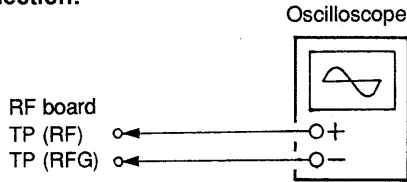

#### Adjustment method:

1. Connect the Oscilloscope to TP (RF) and TP (RFG) on the RF board.
2. Insert the test disc TGYS-1.
3. Press the INPUT SELECTOR key to let "RF mod=CD" appear.  
(RF mode : CD)
4. Press ▷ (PLAY) key to perform repeated playback.
5. Adjust the RV212 on the RF board so that the eye-pattern of the oscilloscope correctly appears.  
(The correct eye-pattern means that  $\diamond$  shape can be identified clearly at the center of waveform.)

An example of RF waveform

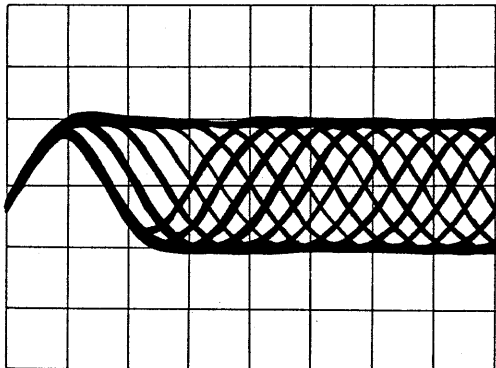

7. Press ■ (STOP) key to stop the playback.
8. Press the EJECT key to take out the test disc.

### Method requiring error rate counter

#### Connection:

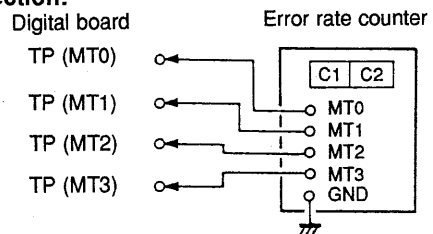

#### Adjustment method:

1. Connect the error rate counter to TP (MT0), TP (MT1), TP (MT2) and TP (MT3) on the digital board.
2. Insert the test disc TGYS-1.
3. Press the INPUT SELECTOR key to let "RF mod=CD" appear.  
(RF mode : CD)
4. Press ▷ (PLAY) key to let "C PLAY-MID" appear. (middle circumference repeated playback)
5. Turn the RV212 on the RF board so that the error rate (C1) of the error rate counter becomes 200 at two points. Measure these two points and adjust the RV212 to the mechanical center.

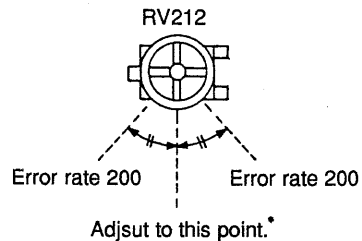

7. Press ■ (STOP) key to stop the playback.
8. Press the EJECT key to take out the test disc.

## 8-11. ERROR RATE CONFIRMATION

### Connection:

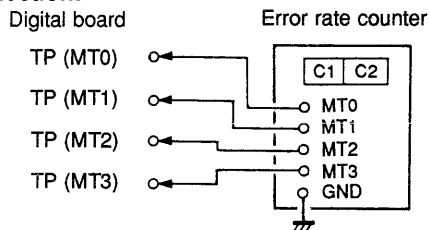

### CD error rate confirmation:

1. Connect the error rate counter to TP (MT0), TP (MT1), TP (MT2) and TP (MT3) on the digital board.
2. Insert the test disc TGYS-1.
3. Press the INPUT SELECTOR key to let "RF mod=CD" appear. (RF mode : CD)
4. Press ▷ (PLAY) key to let "C PLAY-MID" appear. (middle circumference repeated playback)
5. Confirm that the error rate (C1) of the error rate counter is less than 20.
6. Press ■ (STOP) key to stop the playback.
7. Press the EJECT key to take out the test disc.

### MO repeated recording disc making:

1. Insert a standard product MO disc (blank disc).
2. Press the INPUT SELECTOR key to let "RF mod=MO" appear. (RF mode : MO)
3. Press the YES key to move the sled to outer circumference.
4. Press the POWER key to let "CREC-MID" appear. (middle circumference continued recording)
5. Press ▷ (PLAY) key to start recording. (End the recording within one minute.)
6. Press ■ (STOP) key to stop the recording.
7. Press the EJECT key to take out the test disc.

Performing these steps described above permits continued recorded disc for MO error rate confirmation.

### MO error rate confirmation:

Note: Be sure to use the disc (self recorded/played back) made in above steps.

1. Connect the error rate counter to TP (MT0), TP (MT1), TP (MT2) and TP (MT3) on the digital board.
2. Insert the continued recorded disc made in above steps.
3. Press the INPUT SELECTOR key to let "RF mod=MO" appear. (RF mode : MO)
4. Press the YES key to move the sled to outer circumference.
5. Press ▷ (PLAY) key to let "C PLAY-MID" appear. (middle circumference continued playback)
6. Confirm that the error rate (C1) of the error rate counter is less than 50.
7. Press ■ (STOP) key to stop the playback.
8. Press the EJECT key to take out the test disc.

## 8-12. ADJUSTMENT LOCATION

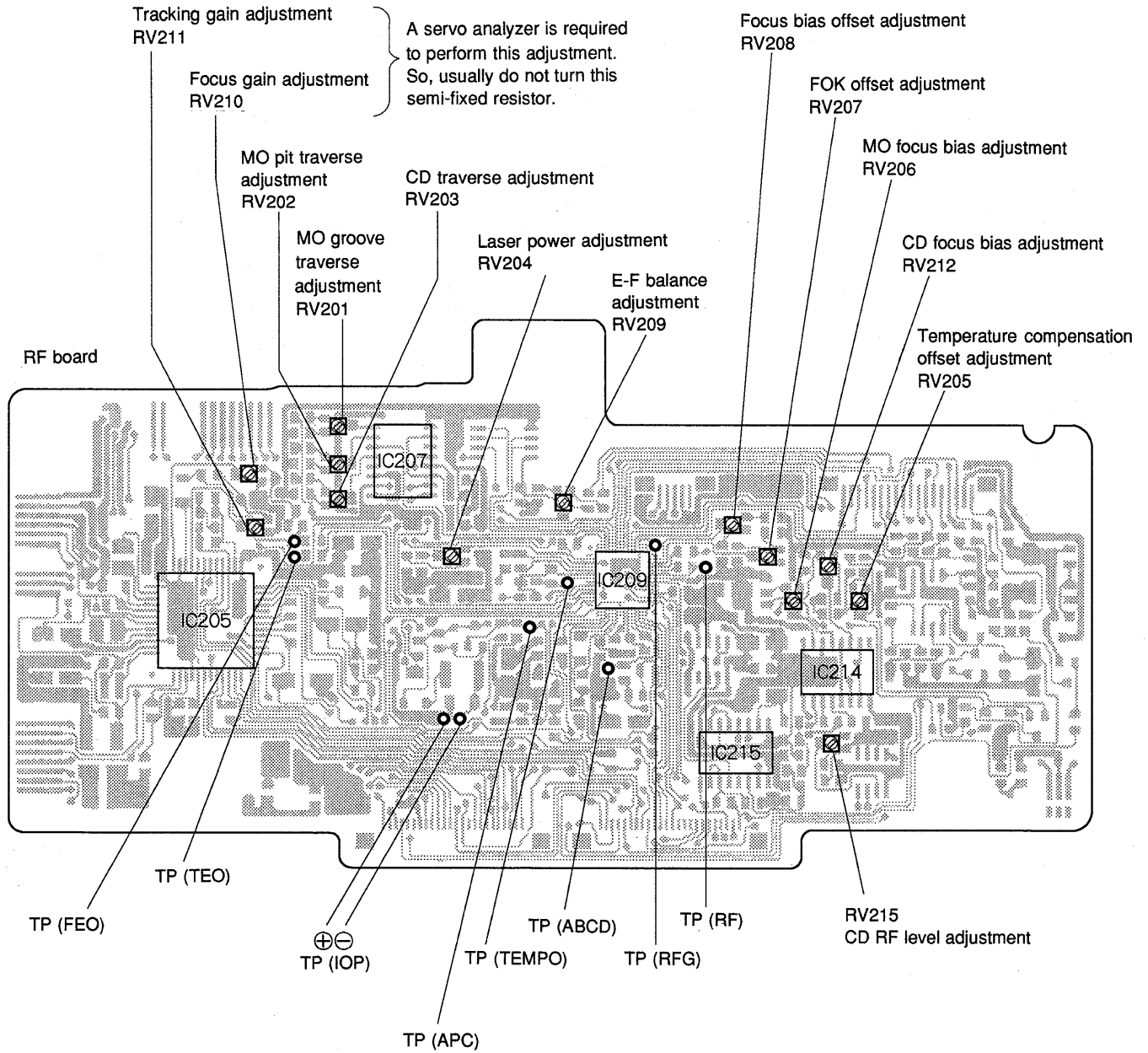

Digital board

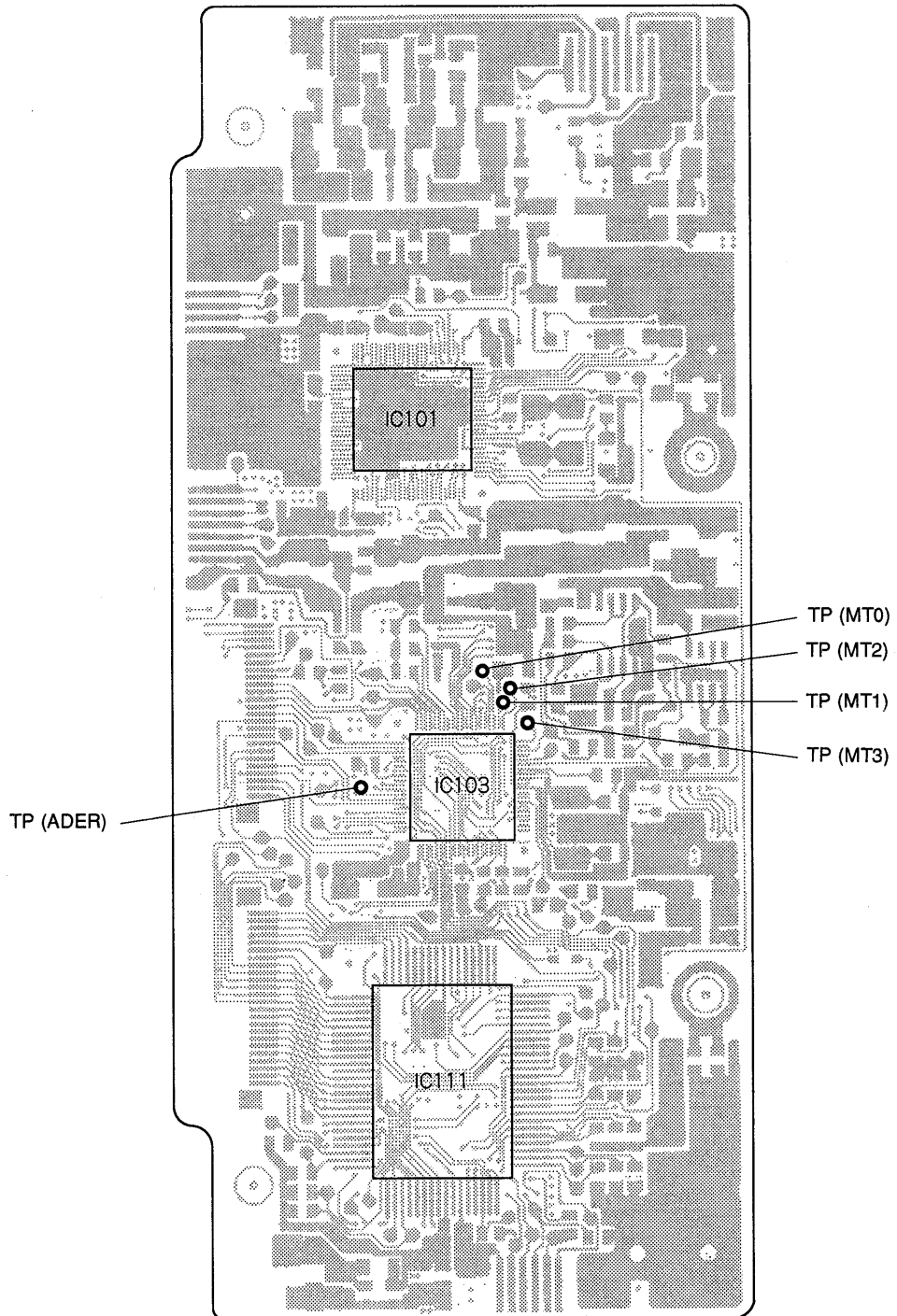



# MDS-101

## SONY SERVICE MANUAL

US Model  
Canadian Model  
AEP Model  
UK Model  
Tourist Model  
Singapore Model

### SUPPLEMENT-2

File this Supplement with the Service Manual.

**Subject :** Change in supply method of parts

 : Changed portion

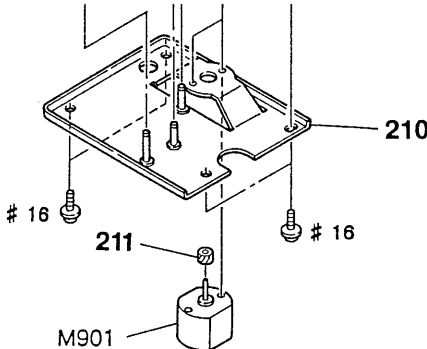
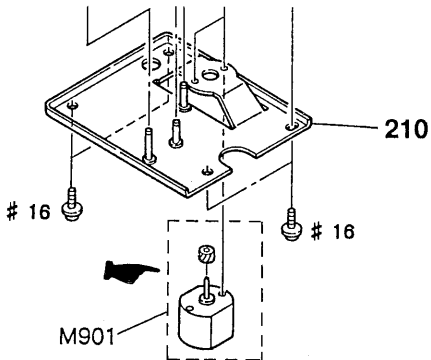
Page	Former	New															
86	 <p>Diagram showing the former assembly with parts 210, # 16, 211, and M901.</p>	 <p>Diagram showing the new assembly with parts 210, # 16, and M901. A callout arrow points to the sled assembly.</p>															
	<table border="1"> <thead> <tr> <th>Ref. No.</th> <th>Parts No.</th> <th>Description</th> </tr> </thead> <tbody> <tr> <td>211</td> <td>4-957-060-01</td> <td>GEAR (PINION D)</td> </tr> <tr> <td>M901</td> <td>1-698-048-21</td> <td>MOTOR, DC (SLED)</td> </tr> </tbody> </table>	Ref. No.	Parts No.	Description	211	4-957-060-01	GEAR (PINION D)	M901	1-698-048-21	MOTOR, DC (SLED)	<table border="1"> <thead> <tr> <th>Ref. No.</th> <th>Parts No.</th> <th>Description</th> </tr> </thead> <tbody> <tr> <td>M901</td> <td>X-4944-046-1</td> <td>MOTOR ASSY, SLED</td> </tr> </tbody> </table>	Ref. No.	Parts No.	Description	M901	X-4944-046-1	MOTOR ASSY, SLED
Ref. No.	Parts No.	Description															
211	4-957-060-01	GEAR (PINION D)															
M901	1-698-048-21	MOTOR, DC (SLED)															
Ref. No.	Parts No.	Description															
M901	X-4944-046-1	MOTOR ASSY, SLED															

# MDS-101

## SONY SERVICE MANUAL

*US Model  
Canadian Model  
AEP Model  
UK Model  
Tourist Model  
Singapore Model*

### CORRECTION-1

Correct your service manual as shown below.

 : indicates corrected portion.

Page	INCORRECT			CORRECT	
	<u>Ref.No.</u>	<u>Part No.</u>	<u>Description</u>	<u>Part No.</u>	<u>Description</u>
86	* 203	1-647-658-11	DETECTION SW BOARD	1-647-648-11 	DETECTION SW BOARD

(SPM-95022)